

BUTADIENE

PRODUCT STEWARDSHIP
GUIDANCE MANUAL

2024



CONTENTS

Legal Notice	1	Piping, Fittings and Valves	25
Purpose and Use of the Manual	2	Storage of Butadiene	26
Figures and Tables	3	Storage System Design and Operations	27
PART I - CHEMICAL IDENTIFICATION		Additional Considerations for Design and	
AND USE	4	Operation of Pressure Storage	28
Product Identification	4	Additional Considerations for Design and	
Uses of Butadiene	4	Operation of Refrigerated Storage	28
General Information	4	Handling, Safety, Health and Toxicity Data	28
Polymer Usage	5	Safe Handling and Disposal of Samples	29
Chemical Intermediate Usage	5	Emission Sources and Controls	29
Chemical and Physical Properties of		Prevention/Control of Undesired Reactions	30
1,3-Butadiene	6	Butadiene Peroxide Formation	30
Butadiene Product Quality	13	Butadiene Popcorn Polymer Formation	32
PART II - HEALTH AND ENVIRONMENTAL		Butadiene Rubber (Plastic) Polymer	
EFFECTS	14	Formation	34
Overview of Butadiene Health Effects	14	Dimerization	36
Acute Inhalation Exposure	14	Reaction from Butadiene Overcharge	37
Eye Contact	14	Butadiene Incompatibilities	37
Skin Contact	14	PART V - FIRE SAFETY AND EMERGENCY	
Chronic Effects	14	RESPONSE	39
4-Vinylcyclohexene Health Effects	15	Fire and Explosion Hazard	39
Potential Environmental Impacts of		Fire Prevention	39
Spills or Releases	15	Fire Fighting	40
PART III - REGULATORY OVERVIEW	16	Response to a Leak	41
PART IV - HANDLING, TRANSPORT AND		APPENDICES	42
STORAGE INFORMATION	17	Appendix A: Butadiene Manufacturing	
Training	17	Process Information	42
Personal Protective Equipment	17	Butadiene Production Via Steam	
Respiratory Protection	17	Cracking of Paraffinic Hydrocarbons	42
Chemical Protective Clothing	19	Butadiene Production via Catalytic	
Eye and Face Protection	19	Dehydrogenation of n-Butane and	
Exposure Monitoring	19	n-Butene (the Houdry process)	45
Charcoal Tube Methods	19	Butadiene Production via Oxidative	
Passive Monitors	19	Dehydrogenation of n-Butenes (the Oxo-D	
Direct Reading, Portable Instruments	20	or O-X-D process)	46
Detector Tubes	20	Processing Options for Crude Butadiene	
Gas Chromatography (GC)	20	Streams	47
Transport of Butadiene	20	Butadiene Recovery from Crude Butadiene	
Transport by Rail Tank Cars	20	Streams Via Extractive Distillation	48
Rail Tank Car Unloading Procedures	21	Appendix B: Information on Product	
Transport by Tank Trucks	24	Safety and Responsible Care®	53
Transport by Marine Vessels	24	Appendix C: References	57
Transport by Bulk Liquid Containers	24	Appendix D: Glossary of Terms,	
Transport by Pipeline	25	Abbreviations, and Organizations	58
Cleaning, Inspection & Repair of			
Transport Equipment	25		



LEGAL NOTICE

The Butadiene Product Stewardship Guidance Manual was prepared by the American Chemistry Council's Olefins Panel (Panel). It is intended to provide general information to persons who may handle or store butadiene. It is not intended to serve as a substitute for in-depth training or specific handling or storage requirements, nor is it designed or intended to define or create legal rights or obligations. It is not intended to be a "how-to" manual, nor is it a prescriptive guide. All persons involved in handling and storing butadiene have an independent obligation to ascertain that their actions are in compliance with current federal, state and local laws and regulations and should consult with legal counsel concerning such matters. The manual is necessarily general in nature and individual companies may vary their approach with respect to particular practices based on specific factual circumstance, the practicality and effectiveness of particular actions, and technological feasibility. Any mention of specific products in this manual is for illustration purposes only and is not intended as a recommendation or endorsement of such products.

*Neither the American Chemistry Council, nor the individual member companies of the Panel, nor any of their respective directors, officers, employees, subcontractors, consultants, or other assigns, makes any warranty or representation, either express or implied, with respect to the accuracy or completeness of the information contained in this manual; nor do the American Chemistry Council or any member companies assume any liability or responsibility for any use or misuse, or the results of such use or misuse, of any information, procedure, conclusion, opinion, product, or process disclosed in this manual. **NO WARRANTIES ARE GIVEN; ALL IMPLIED WARRANTIES OF MERCHANTABILITY OR FITNESS FOR A PARTICULAR PURPOSE ARE EXPRESSLY EXCLUDED.***

This work is protected by copyright. Users are granted a nonexclusive royalty-free license to reproduce and distribute this manual, subject to the following limitations: (1) the work must be reproduced in its entirety, without alterations; and (2) copies of the work may not be sold.

For more information on material presented in this manual, please contact your supplier.

*Copyright © 2019
American Chemistry Council*

PURPOSE AND USE OF THE MANUAL

The members and affiliated companies of the American Chemistry Council support efforts to improve the industry's responsible management of chemicals. To assist in this effort, the American Chemistry Council's Olefins Panel supported the creation and publication of this manual to provide the reader with a better understanding of how butadiene is manufactured and used to produce products that play an important role in our lives.

This manual has been developed for use by producers and industrial users of butadiene. It focuses on the health, safety, and environmental aspects associated with manufacturing, distributing, using, and disposing of 1,3-butadiene. References to applicable regulations and industry practices are made in the tables and text. A Glossary of terms is in Appendix D.

This manual may be updated. Contact your supplier to obtain the most current version of this manual, if you have questions, or for more information about any item contained herein. We encourage comments on the content of this manual and a more in-depth dialogue concerning the issues presented.

FIGURES

- Figure 1.1: Some Uses of 1,3-Butadiene
- Figure 1.2: Liquid Density
- Figure 1.3: Vapor Pressure
- Figure 1.4: Heat of Vaporization
- Figure 1.5: Liquid Heat Capacity
- Figure 1.6: Ideal Gas Heat Capacity
- Figure 1.7: Liquid Viscosity
- Figure 1.8: Vapor Viscosity
- Figure 1.9: Liquid Thermal Conductivity
- Figure 1.10: Vapor Thermal Conductivity
- Figure 1.11: Surface Tension
- Figure 4.1: Growth of Butadiene Popcorn Polymer at 140 °F
- Figure 4.2: Effect of Benzoyl Peroxide and Temperature on Rate of “Rubber” Polymer Formation
- Figure 4.3: Dimerization of 1,3-Butadiene
- Figure A.1: Typical Olefins Plant
- Figure A.2: Catadiene Process
- Figure A.3: Oxo-D Process
- Figure A.4: C4 Processing Options
- Figure A.5: Process A - Acetylene Hydrogenation/Extractive Distillation Using MOPN/Furfural
- Figure A.6: Process B - Extractive and Conventional Distillation Using NMP
- Figure A.7: Process C - DMF Solvent Extraction Process
- Figure A.8: Process D - Aqueous Separation and ACN Extraction Process.

TABLES

- Table 1.1: Use Patterns for 1,3-Butadiene in the US, 2018
- Table 1.2: Chemical and Physical Properties of 1,3-Butadiene
- Table 1.3: Example of a 1,3-Butadiene Specification
- Table 2.1: 1,3-Butadiene Carcinogenicity Classifications
- Table 4.1: Minimum Requirement for Respiratory Protection for Airborne Butadiene (29 CFR § 1910.1051(h)(5)(ii))
- Table 4.2: Summary of Permeation Test Data for 1,3-Butadiene
- Table 4.3: Items Mounted on the Pressure Head Assembly
- Table 4.4: An Example Rail Tank Car Unloading Procedure
- Table 4.5: Items That Should be Considered in Developing a Storage System for Butadiene
- Table 4.6: Effect of Temperature on the Rate of Dimer Formation
- Table 4.7: Chemical Incompatibilities with Butadiene and Potential Outcome
- Table 5.1: General Guidelines for Fire Prevention
- Table A.1: Example of a Crude Butadiene Analysis
- Table A.2: Major Butadiene Recovery Processes

PRODUCT IDENTIFICATION

Product Name	1,3 Butadiene
Chemical Name	1,3 Butadiene
Chemical Family	Diolefins
Chemical Abstract Service Registry Number	106-99-0
Chemical Formula	C ₄ H ₆

USES OF BUTADIENE

General Information

1,3-Butadiene is a major product of the petrochemical industry. Its simple chemical structure combined with its low molecular weight and high chemical reactivity makes it a very useful building block in the synthesis of other materials.

Butadiene is used primarily as a monomer in the production of a wide range of polymers and copolymers. It is also used as an intermediate in the production of several chemicals. Table 1.1 provides a listing of the use patterns for butadiene in the United States.

CHEMICAL STRUCTURE

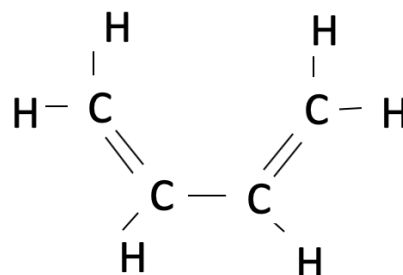

General Description: Butadiene is a colorless gas at room temperature with a characteristic hydrocarbon odor. It is a hazardous chemical due to its flammability, reactivity, and toxicity.

Table 1.1: Use Patterns for 1,3-Butadiene in the US, 2018¹

End-Use of Butadiene, U.S. - 2018	% of Total
Polybutadiene rubber	25%
Styrene-butadiene rubber	23%
Adiponitrile	23%
Styrene-butadiene latex	8%
Thermoplastic elastomer	5%
Acrylonitrile-butadiene-styrene resins	4%
Nitrile rubber	3%
Polychloroprene (neoprene) rubber	3%
Other (includes methyl methacrylate-butadiene-styrene (MBS) resins, styrenic block copolymers, nitrile barrier resins, K-Resin [®] , and specialty polybutadiene polymers, among others)	6%

¹Source: IHS, ACC analysis

Polymer Usage

Polybutadiene (PB): As illustrated in Table 1.1, PB, produced by the polymerization of butadiene, is the largest use of the monomer (approximately 25%). Some of the uses for this polymer are as a raw material for tires, as an intermediate in the production of acrylonitrile-butadiene-styrene (ABS) resin and in impact modifiers. Such impact modifiers enhance the ability of a material to accept a sudden blow or shock without fracture or substantial damage.

Styrene-Butadiene Rubber (SBR): Approximately 23% of the butadiene end-use in the U.S., is in the production of SBR. Produced by the polymerization of styrene and butadiene, the primary use of SBR is in tires and tire products. This material also is used in adhesives and sealants, coatings for wire and cable and many other rubber articles such as shoe soles.

Styrene-Butadiene Latex (SBL): SBLs comprise about 8% of the butadiene end-use in the U.S. Latex, in general, can be described as a stable aqueous dispersion, which contains discrete polymer particles of approximately 0.05 to 5 micrometers in diameter. SBL applications include foam rubber (carpet backing, cushions, pads, sponges, etc.), adhesives (floorings, tiles, road and roofing, etc.), sealants and paper coatings.

Acrylonitrile-Butadiene-Styrene (ABS) Resins: ABS resins are two-phase blends. They can be prepared by either emulsion polymerization or suspension grafting polymerization where homopolymers of polybutadiene are grafted onto a styrene-acrylonitrile copolymer. The production of ABS resins account for about 4% of the butadiene usage in the U.S. These resins are used in a wide range of applications that include automotive parts, telephones, office machines such as computers, and appliances.

Nitrile Rubber (NBR): NBR is produced by the copolymerization of acrylonitrile and butadiene. It also is referred to as nitrile-butadiene rubber. NBR accounts for about 3% of the butadiene consumption in the United States. This material is used in a variety of products including hoses,

fuel lines, automotive parts, gasket seals, lattices, structural adhesives, oil resistant clothing or articles, gloves and footwear.

Styrene-Butadiene Block Copolymers (SBS and SEBS): Blocks of styrene, butadiene and styrene are polymerized to form styrene-butadiene-styrene (SBS) block copolymers. Similarly, blocks of styrene, ethylene/butylene and styrene form SEBS block copolymers. End uses for these thermoplastic materials include asphalt extenders, lubricating oil additives, adhesives, automotive applications, food and other types of packaging, medical devices, footwear, toys, disposable dinnerware and polymer modification such as impact modifiers.

Methyl Methacrylate-Butadiene-Styrene (MMBS): MMBS resin is used as an impact modifier in automotive parts, bottles and food packaging.

Chemical Intermediate Usage

1,3-Butadiene also is used in the production of a number of intermediate chemicals.

Adiponitrile >> Hexamethylenediamine >> Nylon: The production of the chemical intermediate adiponitrile is the largest use of 1,3-butadiene in this type of application. This represents approximately 23% of the overall butadiene usage. One method employed to produce adiponitrile involves the direct hydrocyanation of butadiene followed by hydrocyanation of the pentenenitrile compounds produced in the butadiene reaction. This material is then hydrogenated to form hexamethylenediamine, which is polymerized in the manufacture of nylon resins and fibers.

Chloroprene: Chloroprene is formed by chlorinating butadiene. This material is then polymerized to produce neoprene. Neoprene rubber is a multipurpose material that accounts for about 3% of the butadiene usage. It is used in applications that include gloves, coatings, adhesives, binders, sealants, tires, belts, hoses, faucet washers and footwear.

Other Chemical Intermediate Uses: Butadiene also is used in the production of 1,4-hexadiene,

sulfolane and 1,5,9-cyclodecatriene. 1,4-hexadiene is primarily used as the monomer for ethylene-propylene terpolymer (EPDM); sulfolane is an extraction solvent, and 1,5,9-cyclodecatriene is used in the production of nylon fibers and resins.

In summary, 1,3-butadiene is an extremely versatile and significant industrial chemical. Figure 1.1 provides an overview of some uses of 1,3-butadiene.

Figure 1.1: Some End Uses of 1,3-Butadiene

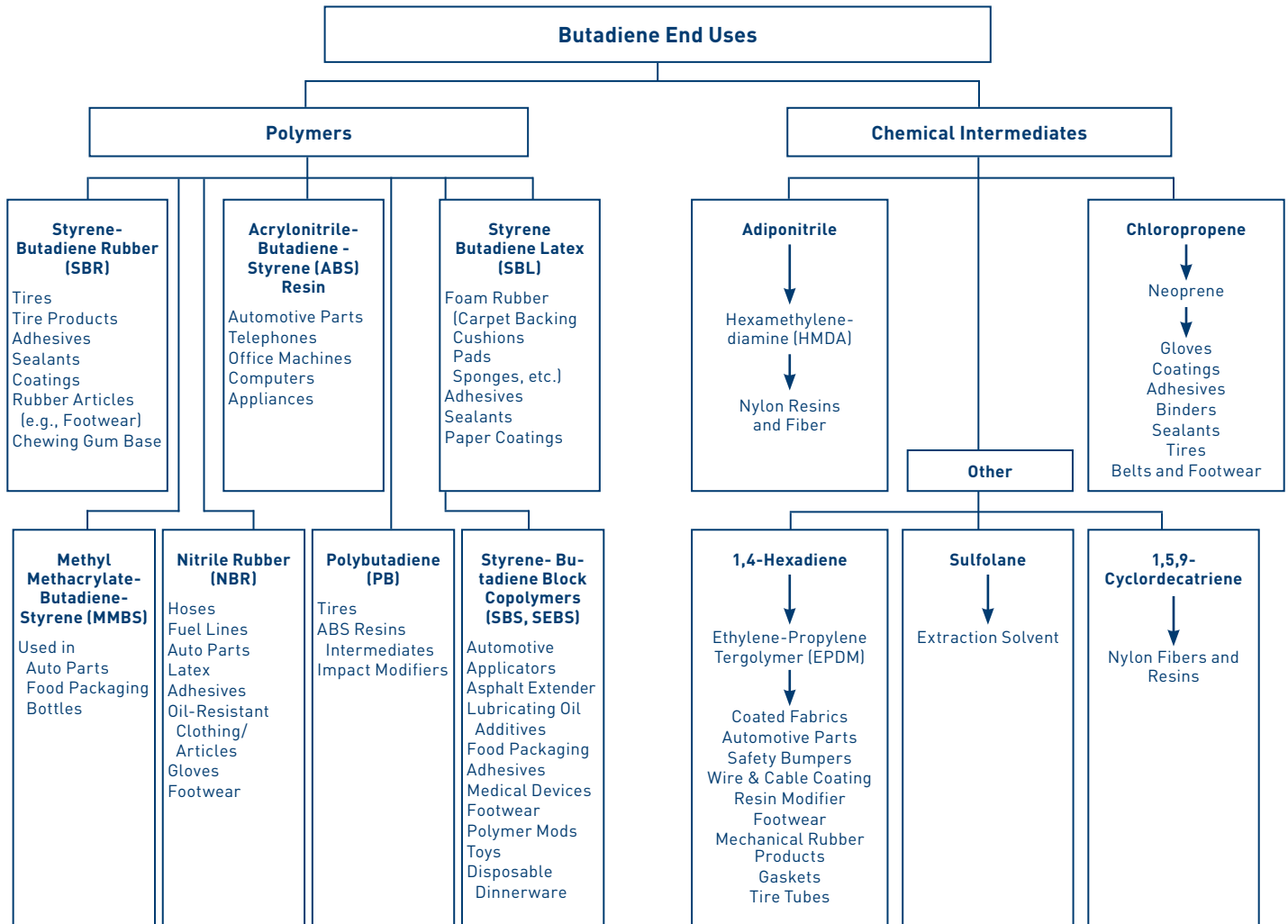

Chemical and Physical Properties of 1,3-Butadiene

1,3-Butadiene is a colorless, non-corrosive, flammable gas with a hydrocarbon odor at ambient temperature and pressure. Data pertaining to its chemical and physical properties are presented in Table 1.2. Additional data concerning the physical properties of butadiene and their temperature dependence can be found in Figures 1.10-1.19 (Source: AIChE DIPPR® Database unless otherwise indicated).

Table 1.2: Chemical and Physical Properties of 1,3-Butadiene

Property	Value
Physical State	Gas, Liquid Under Pressure
Color	Colorless
Odor	Mild, Aromatic (Hydrocarbon)
Molecular Formula	C ₄ H ₆
Molecular Weight	54.09
Normal Boiling Point (at 1 atmosphere)	24.1°F
Melting Point	-164°F
Critical Temperature	305.6°F
Critical Pressure	620.3 psia
Critical Volume	0.065 ft ³ /lb
Critical Compressibility Factor	0.267
Density (liquid), @70°F	38.74 lb/ft ³ (5.18 lb/gal)
Relative Vapor Density (gas) air - 1) ²	1.87
Vapor Pressure, @ 70°F	36.1 psia
Liquid Heat Capacity, @70°F	0.541 BTU/lb°F
Ideal Gas Heat Capacity, @70°F	0.347 BTU/lb°F
Refractive Index, n _D , @70°F	1.4293
Solubility in Water, @70°F	735 ppm
Partition Coefficient n-Octanol/Water ³	Log Pow 1.99
Viscosity (liquid), @70°F	9.90 x 10 ⁻⁵ lb/ft*s
Viscosity (vapor), @70°F	5.65 x 10 ⁻⁶ lb/ft*s
Ideal Gas Heat of Formation	869.1 BTU/lb
Heat of Vaporization, @70°F	167.0 BTU/lb
Autoignition Temperature	803.9°F
Explosive Limits in Air, Vol. % @77°F, 1 atm	
Lower	2.0
Upper	11.5
Odor Threshold in Air	
Recognition ⁴	1.0-1.6 ppm
Detection ³	0.025 ppm

²Verschueren, K., Handbook of Environmental Data of Organic Chemicals, 2nd ed., New York, NY: Van Nostrand Reinhold Co., 1983, p. 296.

³Hansch, C., Leo, A. Substituent Constants for Correlation Analysis in Chemistry and Biology. New York, NY: John Wiley and Sons, 1979, p.183.

⁴Hansch, C., Leo, A. Substituent Constants for Correlation Analysis in Chemistry and Biology. New York, NY: John Wiley and Sons, 1979, p.183.

Figure 1.2: Liquid Density

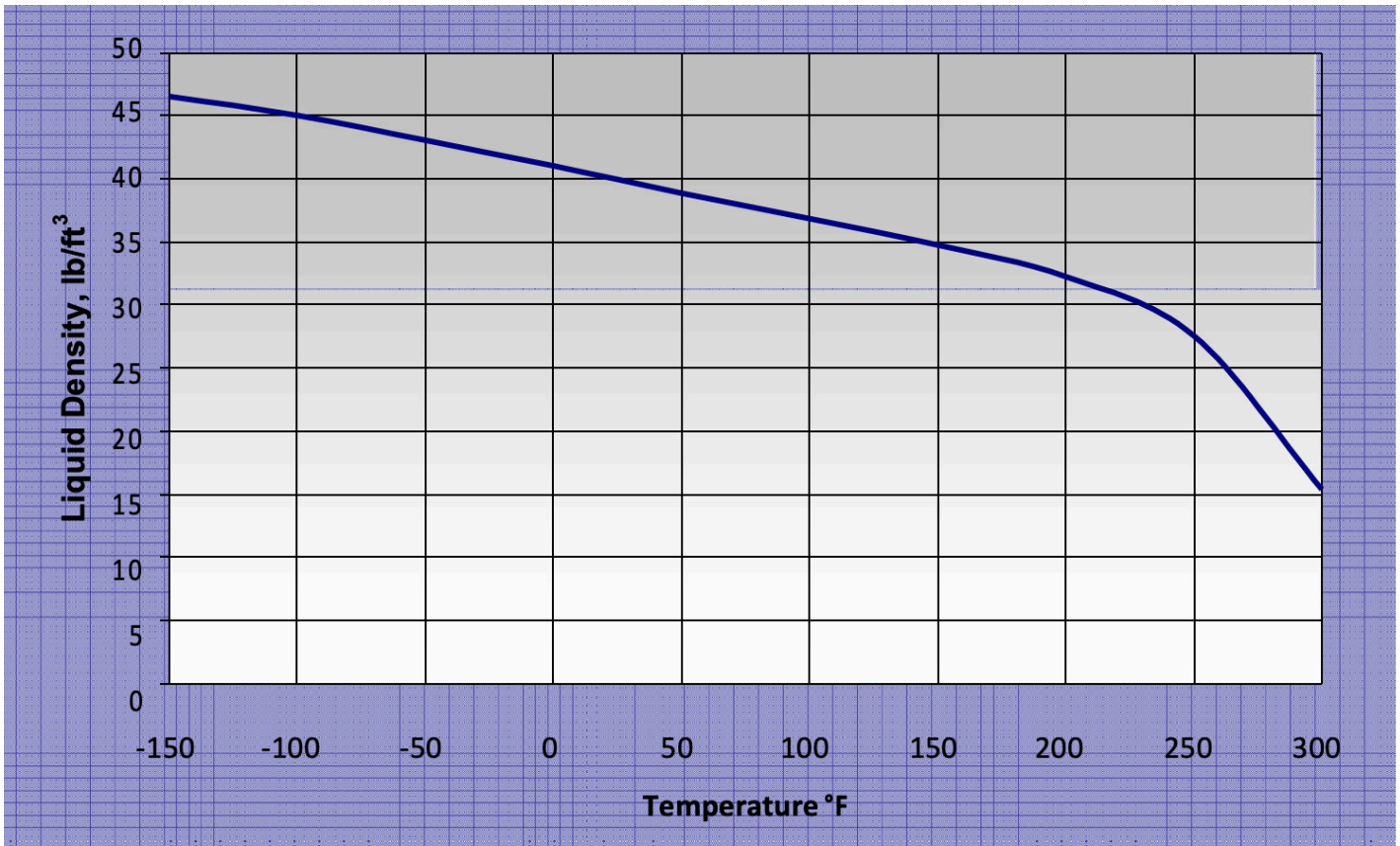

Figure 1.3: Vapor Pressure

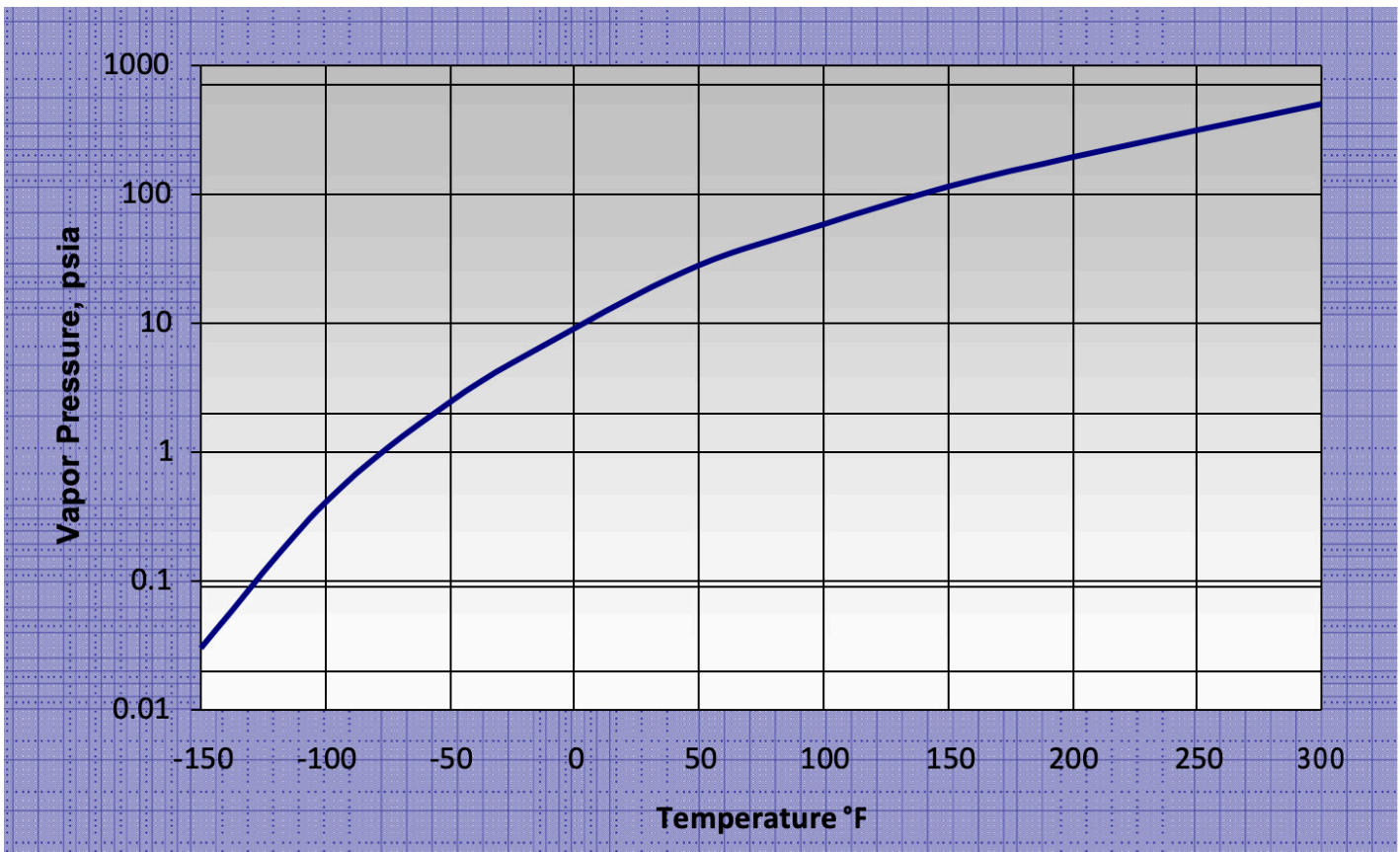

Figure 1.4: Heat of Vaporization

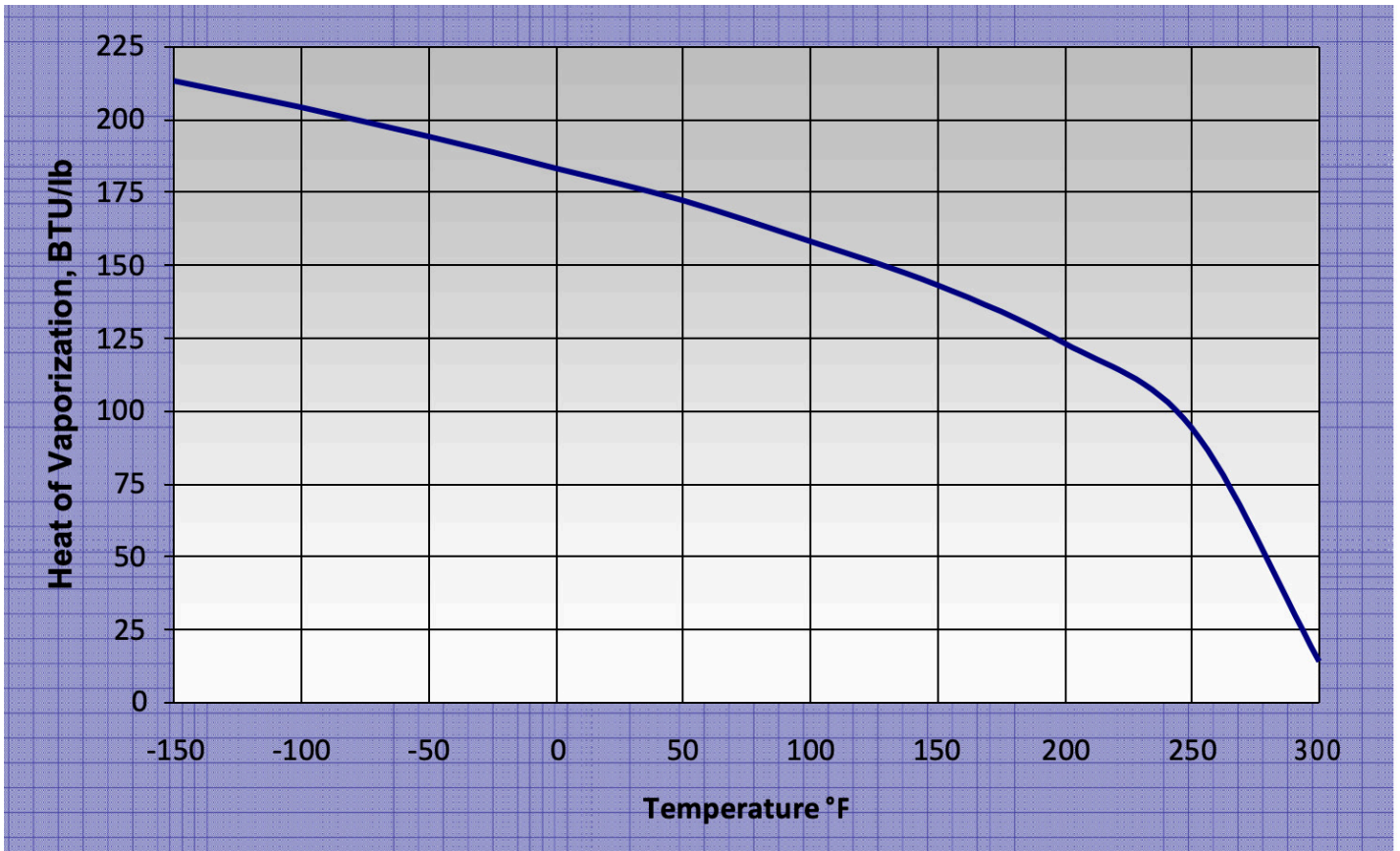

Figure 1.5: Liquid Heat Capacity

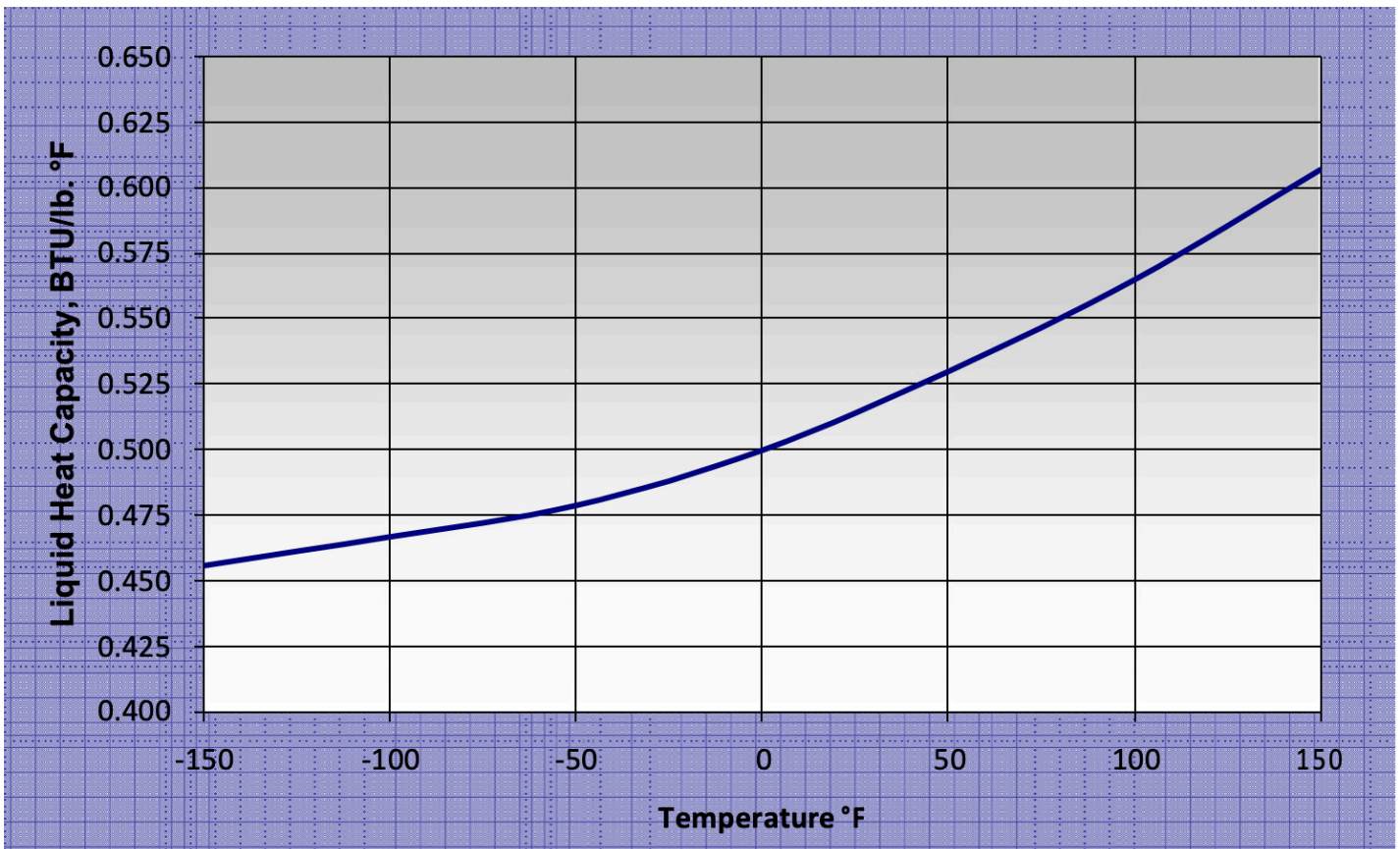

Figure 1.6: Ideal Gas Heat Capacity

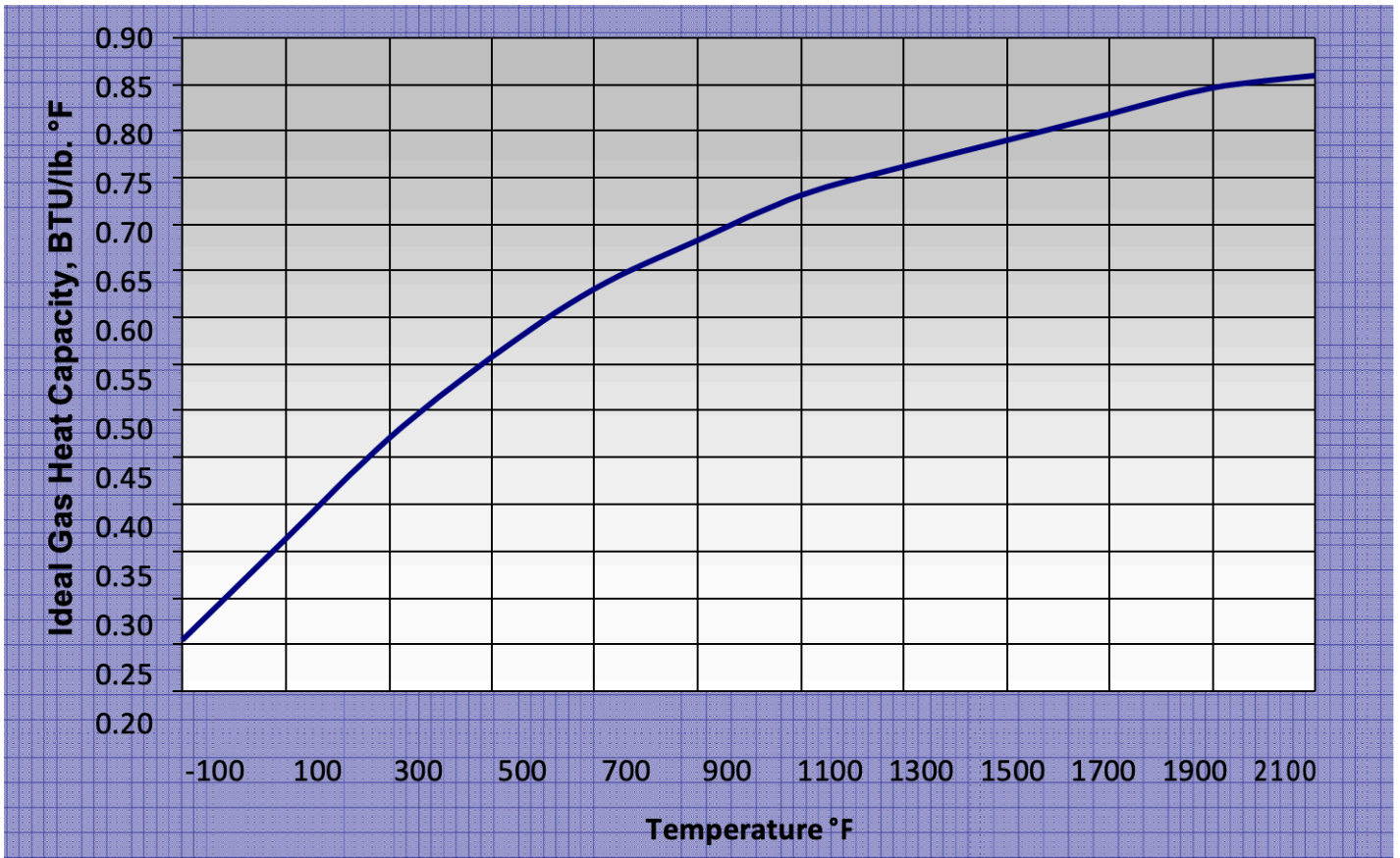

Figure 1.7: Liquid Viscosity

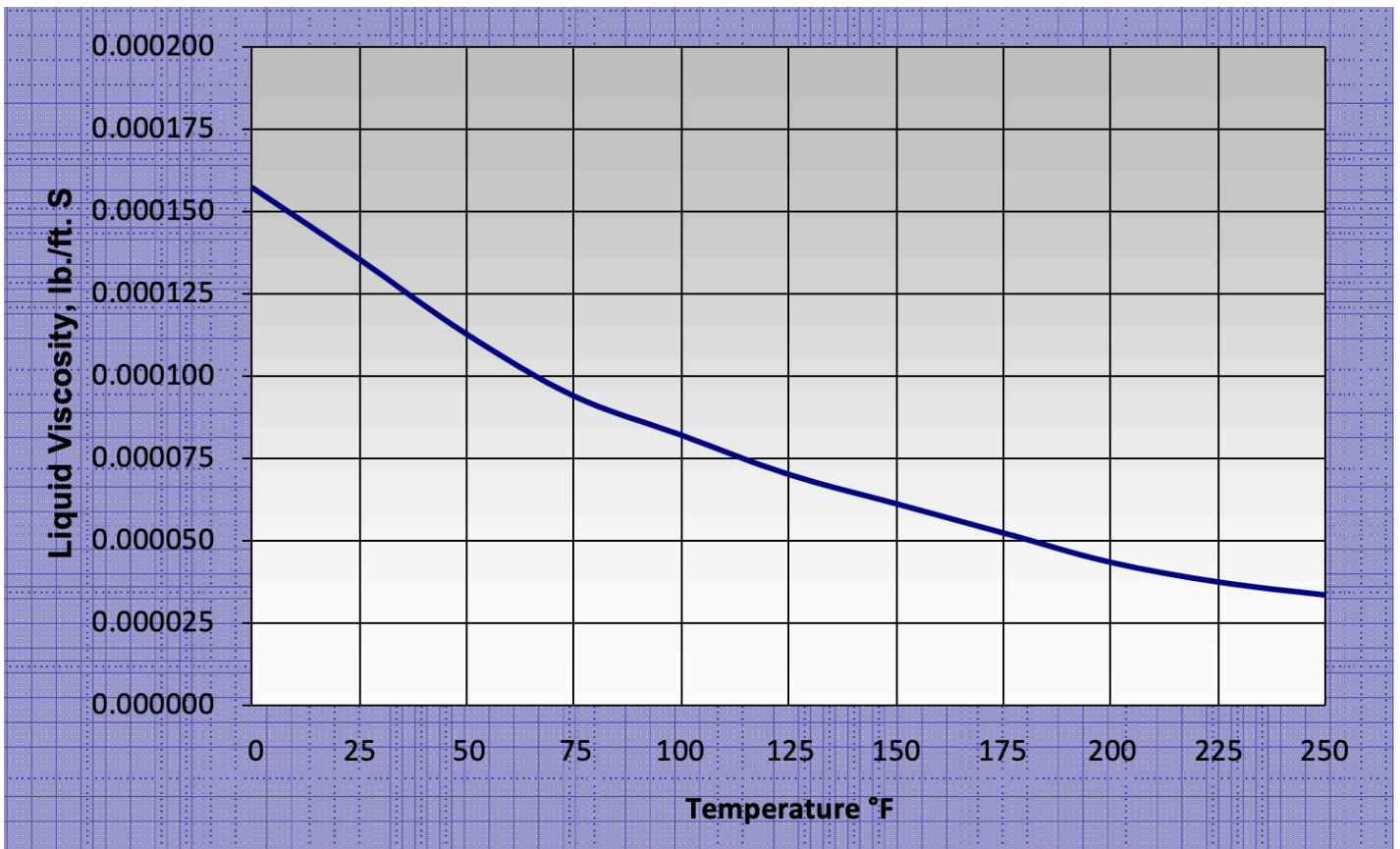

Figure 1.8: Vapor Viscosity

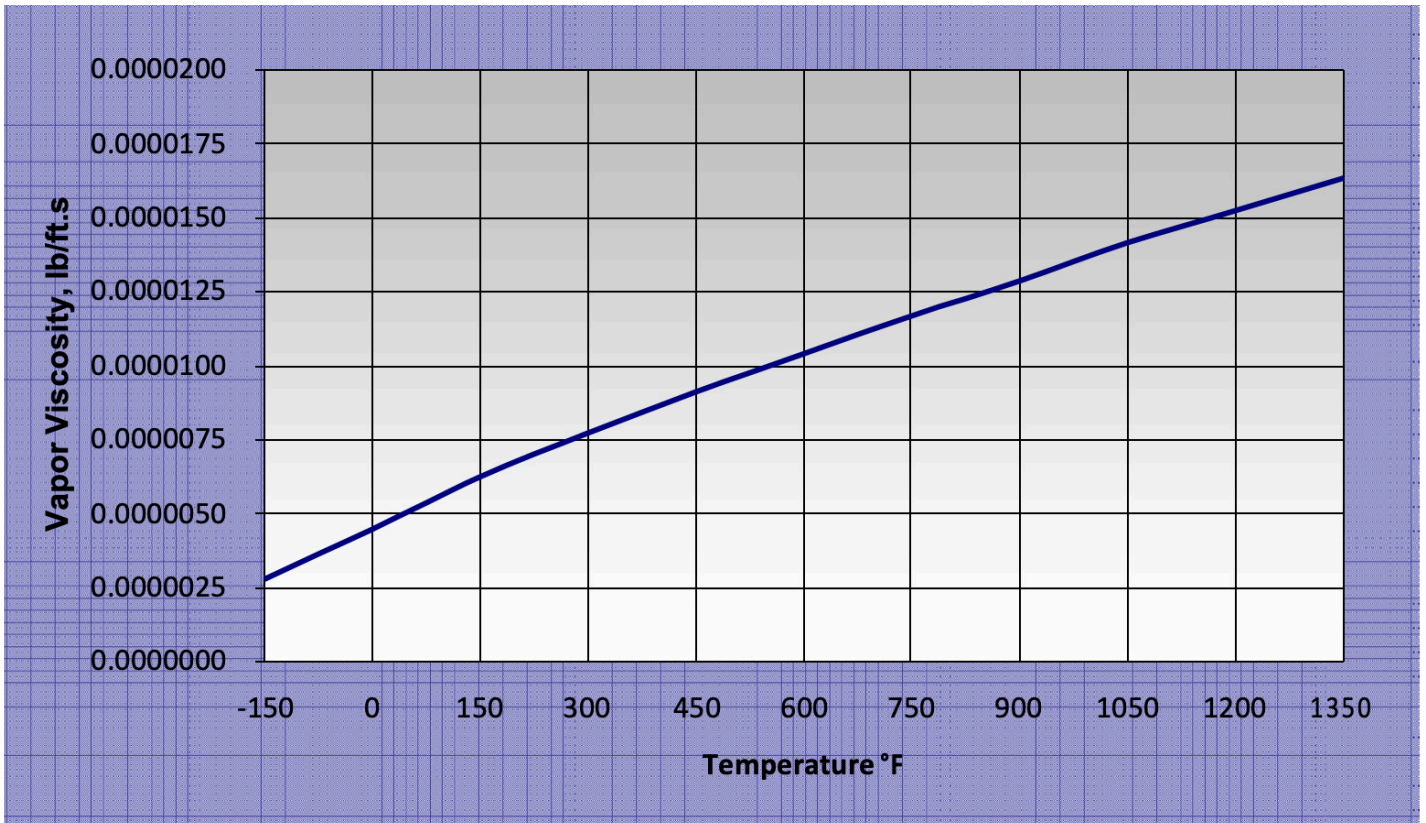

Figure 1.9: Liquid Thermal Conductivity

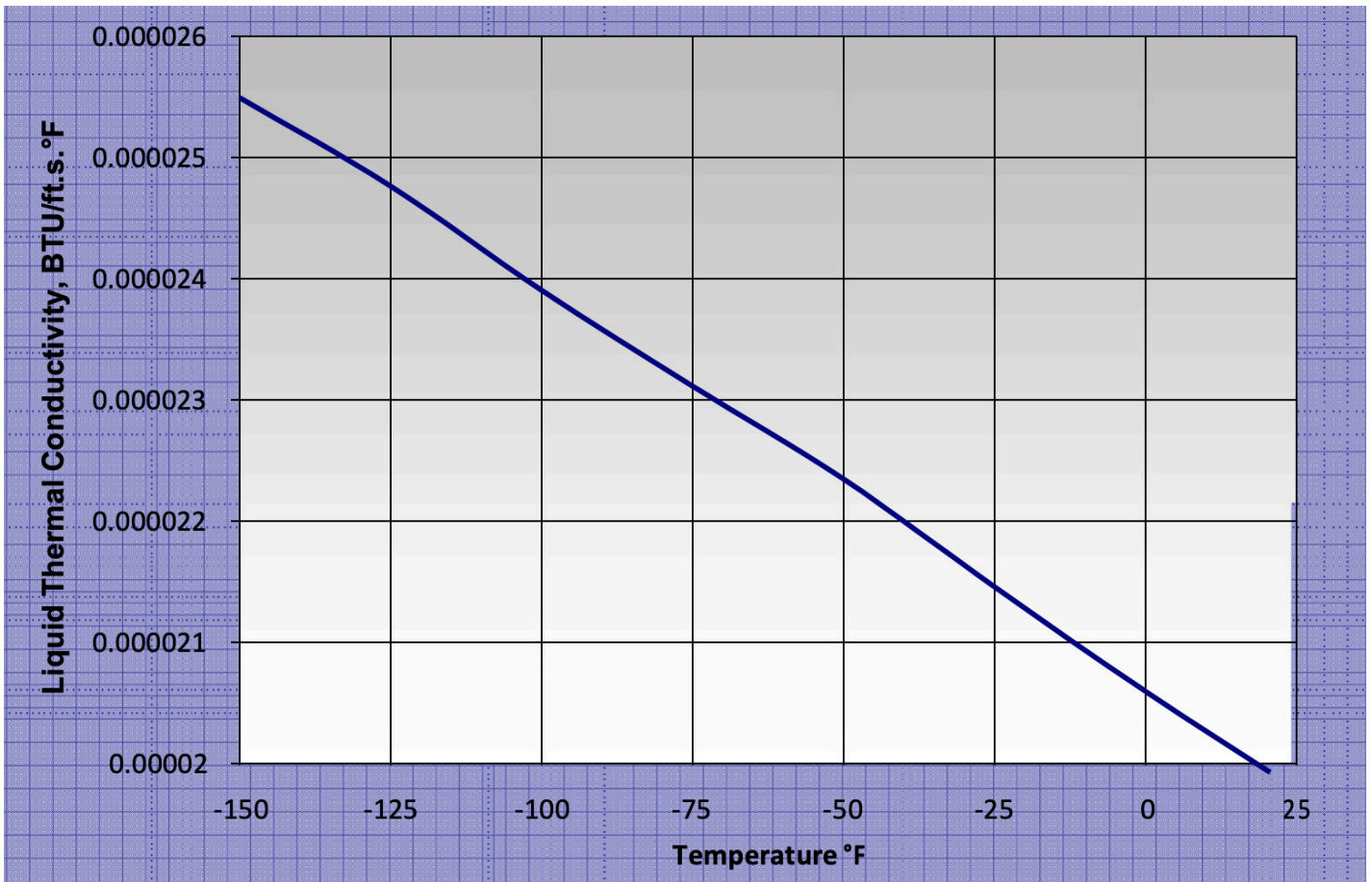

Figure 1.10: Vapor Thermal Conductivity

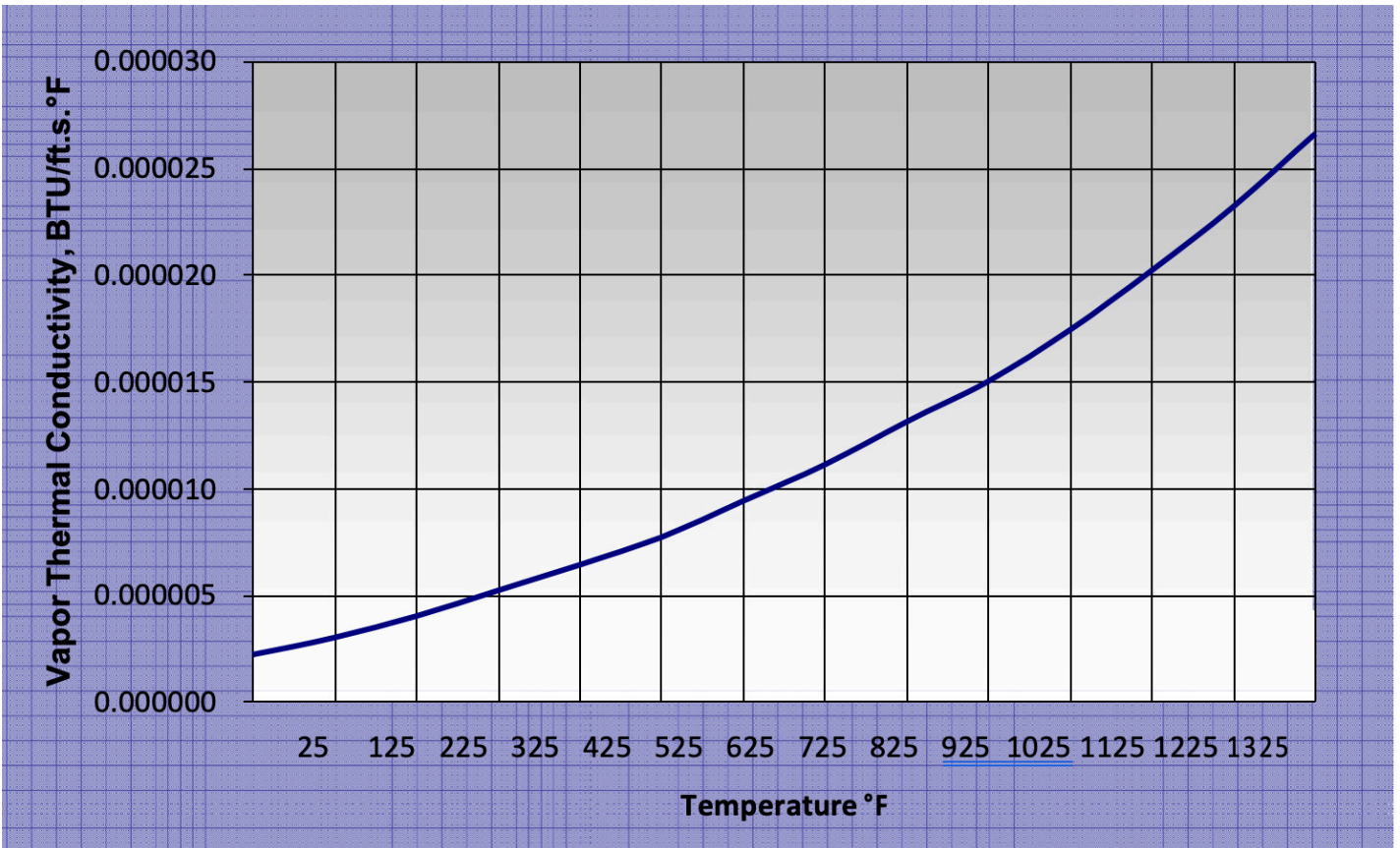
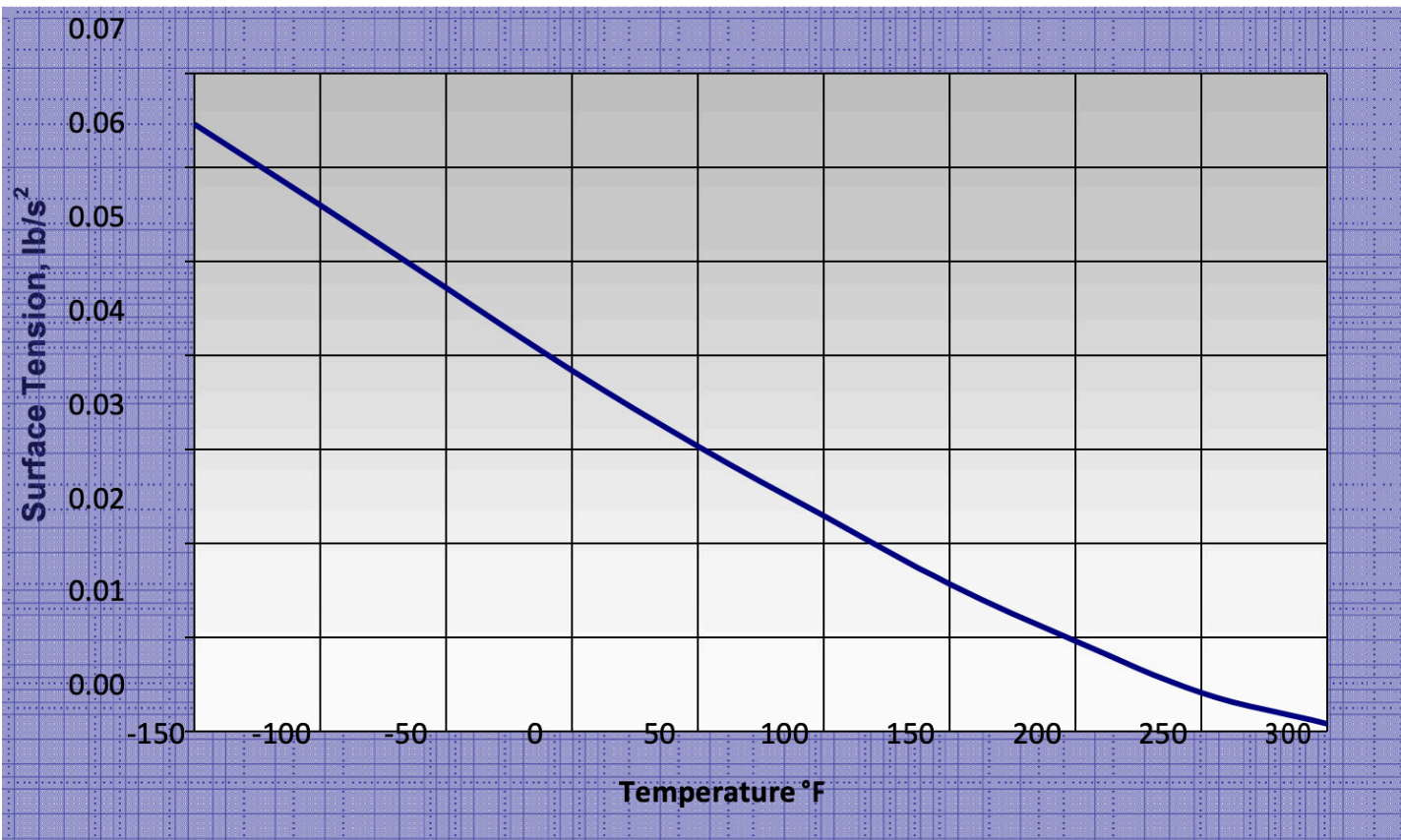

Figure 1.11: Surface Tension



BUTADIENE PRODUCT QUALITY

Table 1.3 shows an example of a butadiene specification. Individual company specification limits may differ from those given in the table.

Table 1.3: Example of a 1,3-Butadiene Specification

Component	Limits	Spec.	Acceptable Test Methods -- Generic
Butadiene-1,3 as Received	Wt. % Min.	99.5	D2593 Mod.
Butene-1 & Isobutylene	Wt. %	Report	D2593 Mod.
Trans-Butene-2	Wt. %	Report	D2593 Mod.
Cis-Butene-2	Wt. %	Report	D2593 Mod.
Butadiene-1,2	Wppm Max.	20	D2593 Mod.
Propadiene	Wppm Max.	10	D2593 Mod.
Butadiene Dimer as	Wppm Max.	500	D2426 Mod. Shipped
C5s	Wppm Max.	500	D2593 Mod., D2426 Mod.
Pentadiene	Wppm Max.	5	D2593 Mod.
Isoprene	Wppm Max.	10	D2593 Mod.
Total Acetylenes	Wppm Max.	20	D2593 Mod.
Ethyl Acetylene	Wppm	Report	D2593 Mod.
Methyl Acetylene	Wppm	Report	D2593 Mod.
Vinyl Acetylene	Wppm	Report	D2593 Mod.
Non-Volatile Residue	Wt. % Max	0.05	D1025 Mod.
Carbonyls (Reported as Acetaldehyde)	Wppm Max.	10	D4423 Mod., Gas Chromatography, HPLC
Methanol	Wppm Max.	10	UOP569 Mod
Toluene	Wppm Max.	10	GC
Organic Chlorides (Exported as Chloride)	Wppm Max.	10	UOP779 Mod., UOP606 Mod., GC
Sulfur	Wppm Max.	5	D4045 Mod., D4468 Mod., D2784 Mod., D3246 Mod.
Total Atomic Nitrogen	Wppm Max.	2	D4629 Mod.
Diethylhydroxylamine	Wppm Max.	2	Hach, GC
Peroxides (Reported as H2O2)	Wppm Max.	5	AMS 3001.10 Mod.
TBC Inhibitor *	Wppm	50 - 150	D1157 Mod., AM330.28 Mod.
Oxygen in Vapors	Vol. % Max.	0.1	Teledyne
Water	Wppm Max.	500	Panametrics Dew Point
Appearance	Clear & Free Visual	None	

*Other inhibitors are used but TBC is the current industry-wide recognized standard for 1, 3 Butadiene storage and transportation.

OVERVIEW OF BUTADIENE HEALTH EFFECTS

This section provides a brief overview of information pertaining to potential health and environmental effects associated with exposure to 1,3-butadiene. A comprehensive discussion of health and environmental effects pertaining to 1,3-butadiene is beyond the scope of this manual. For more information, contact your supplier. Additional information, including first aid information, can be found in your supplier's Safety Data Sheet (SDS).

Acute Inhalation Exposure

Butadiene vapors may be mildly irritating to the nose, throat and respiratory tract. High vapor concentrations may cause central nervous system (CNS) depression. Early to moderate CNS depression may be evidenced by giddiness, headache, dizziness and nausea; in extreme cases, unconsciousness, respiratory depression and death may occur.

High concentrations of butadiene in confined spaces, such as may occur in a spill or leak situation, may cause asphyxiation by displacing the oxygen, causing an oxygen-deficient atmosphere. As with the above CNS effects, this can result in a sudden loss of consciousness and potentially death.

Eye Contact

Eye contact with rapidly expanding butadiene gas or vaporizing liquid butadiene may cause severe irritation and burns (frostbite). Frostbite results from the cooling effect of rapid evaporation of the material.

Skin Contact

Skin contact with rapidly expanding butadiene gas or vaporizing liquid butadiene may cause irritation and burns (frostbite). Exposure to high vapor concentrations may cause slight irritation to the skin.

Chronic Effects

The potential for 1,3-butadiene to cause cancer or other chronic health effects has been examined in experiments using laboratory animals and also by studying exposed human populations. Examples of cancer classifications established by various governmental entities as of the date of publication of this manual are listed in Table 2.1.

Other potential target organs for exposure to 1,3-butadiene may include the liver, kidneys, respiratory tract, ovaries, testes and hematopoietic system (blood forming organs). Laboratory mice have been shown to be highly sensitive to 1,3-butadiene, including the endpoints of cancer, developmental toxicity (effects on the developing fetus) and injury to reproductive organs. The relevance of the findings in mice to humans is the subject of ongoing research by numerous investigators, including studies sponsored by the American Chemistry Council's Olefins Panel. For more information concerning potential chronic hazards from exposure to 1,3-butadiene, contact your supplier.

Table 2.1: 1,3-Butadiene Carcinogenicity Classifications

Organization	Classification
International Agency for Research on Cancer (IARC)	Group 1 – Carcinogenic to Humans
Environmental Protection Agency (EPA)	Carcinogenic to Humans by Inhalation
National Toxicology Program (NTP)	Known Human Carcinogen
National Institute for Occupational Safety and Health (NIOSH)	Carcinogen, with No Further Categorization
American Conference on Governmental Industrial Hygienists (ACGIH)	Group A2 – Suspected Human Carcinogen

Revised 11/22/16

4-Vinylcyclohexene Health Effects

4-Vinylcyclohexene (4-VCH) is a dimer of 1,3-butadiene and is normally present in butadiene. It is generally controlled below the 500-1000 ppmw level per product specifications. Studies in mice and rats show that mice have greater sensitivity to 4-VCH than rats, and are more efficient at converting 4-VCH to toxic metabolites and less effective at eliminating those toxic metabolites. Effects in mice include uncommon ovarian tumors and other effects on the ovaries and testes. Additional information about the health effects of 4-VCH can be obtained from your supplier.

Potential Environmental Impacts of Spills or Releases

1,3-Butadiene is expected to rapidly volatilize into the air from water or soil and is not expected to be persistent in the air. The primary reaction for butadiene in air is with photochemically produced hydroxyl radicals – the estimated half-life is on the order of a few hours. Other reactions with butadiene that are expected to occur in the atmosphere are with ozone and nitrate radicals. The atmospheric half-life of 1,3-butadiene with ozone has been estimated at a few hours to a few days. No data are available on aquatic toxicity due to the high volatility and low water solubility of 1,3-butadiene. Water concentrations are not expected to be significant.



Regulations may exist that govern the manufacture, sale, transportation, use, and/or disposal of butadiene. These regulations may vary by city, state, country, or geographic region. For additional information, contact your supplier, consult your supplier's Safety Data Sheet (SDS), or consult with the appropriate regulatory agency or your legal counsel.

HANDLING, TRANSPORT AND STORAGE INFORMATION



Training

Any person who comes into contact with butadiene should be trained in proper handling and safety per applicable federal, state and local laws and regulations.

Personal Protective Equipment

Respiratory Protection

Respiratory protection should be used in accordance with company and applicable regulatory requirements.

OSHA's 1,3-butadiene standard requires engineering controls and work practices that comply with the OSHA PELs unless infeasible or work operations are non-routine. Engineering controls and work practices which are not sufficient to reduce exposures below the PELs should remain in place to reduce employee exposure to the lowest level achievable. Respiratory protection should be used to supplement the engineering controls and work practices. Table 4.1 details the minimum requirements for respiratory protection for airborne butadiene as contained in OSHA's 1,3-Butadiene Standard.

Persons should not be assigned to tasks requiring the use of respirators unless it has been determined they are physically able to perform the work and are trained to use the equipment.

Chemical Protective Clothing

The purpose of chemical protective clothing (CPC) is to prevent contact with chemicals that can injure or be absorbed through the skin. As indicated in Part II of this manual, skin contact with liquefied butadiene may result in frostbite.

The level of protection selected should be based on the potential butadiene concentration and likelihood of contact. It could range from no CPC being required, such as when butadiene is handled in closed systems and there is no personnel exposure, to fully encapsulating suits with supplied-air respirators in certain spill situations.

To assist in the selection of CPC, Table 4.2 contains butadiene permeation test results for many of the most common CPC materials. Although the data in the table has been compiled from published sources, it has not been independently verified. The table should not be considered a complete list of all permeation test data for materials with 1,3-butadiene. When selecting specific products, the material manufacturer should be contacted. In addition to permeation properties, thermal insulating properties for protection against frostbite may be a consideration in CPC material selection.

Table 4.1: Minimum Requirement for Respiratory Protection for Airborne Butadiene (29 CFR § 1910.1051(h)(3)(i))

Concentration of Airborne Butadiene (ppm)	Minimum Required Respirator or Condition of Use
Less than or equal to 5 ppm (5 times PEL)	(a) Air-purifying half mask or full facepiece respirator equipped with approved BD or organic vapor cartridges or canisters. Cartridges or canisters shall be replaced every 4 hours.
Less than or equal to 10 ppm (10 times PEL)	(a) Air-purifying half mask or full facepiece respirator equipped with approved BD or organic vapor cartridges or canisters. Cartridges or canisters shall be replaced every 3 hours.
Less than or equal to 25 ppm (25 PEL)	<p>(a) Air-purifying full facepiece respirator equipped with times approved BD or organic vapor cartridges or canisters. Cartridges or canisters shall be replaced every 2 hours.</p> <p>(b) Any powered air-purifying respirator equipped with approved BD or organic vapor cartridges. PAPR cartridges shall be replaced every 2 hours.</p> <p>(c) Continuous flow supplied air respirator equipped with a hood or helmet.</p>
Less than or equal to 50 ppm (50 PEL)	<p>(a) Air-purifying full facepiece respirator equipped with times approved BD or organic vapor cartridges or canisters. Cartridges or canisters shall be replaced every (1) hour.</p> <p>(b) Powered air-purifying respirator equipped with a tight-fitting facepiece and an approved BD or organic vapor cartridges. PAPR cartridges shall be replaced every (1) hour.</p>
Less than or equal to 1,000 ppm (1,000 times PEL)	(a) Supplied air respirator equipped with a half mask or full facepiece operated in a pressure demand or other positive pressure mode.
Greater than 1,000 ppm or unknown concentration or firefighting	<p>(a) Self-contained breathing apparatus equipped with a full facepiece and operated in a pressure demand or other positive pressure mode.</p> <p>(b) Any supplied respiratory equipment with full facepiece and operated in a pressure demand or other positive pressure mode in combination with an auxiliary self-contained breathing apparatus operated in a pressure demand or other positive pressure mode.</p>
Escape from Immediately Dangerous Life or Health (IDLH) conditions	(a) Any positive pressure self-contained breathing apparatus to with an appropriate service life. (b) A air-purifying full facepiece respirator equipped with a front or back mounted BD or organic vapor canister.

Notes: Respirators approved for use in higher concentrations are permitted to be used in lower concentrations. Full face piece is required when eye irritation is anticipated.

Table 4.2: Summary of Permeation Test Data for 1,3-Butadiene⁵⁶⁷⁸

Resistant Material	Breakthrough Time (hrs)	Permeation Rate ug/cm ² /min	Thickness
Butyl	>8.00	N/A ⁹	.07 cm
Natural Rubber	<0.02	637.27	.02 cm
Neoprene	0.78	1.80	.05 cm
PVC	<0.02	126.25	.02 cm
Tychem® BR	8.00	<.02	18 mils
Tychem® TK	8.00	<.07	25 mils
TRELLCHEM® EVO	>24.00	<.03	2 mils

Eye and Face Protection

Appropriate eye and face protection may be necessary to prevent contact with butadiene. A hazard assessment conducted in accordance with the requirements of the OSHA standard for Personal Protective Equipment (29 CFR § 1910.132) can help to determine the level of protection necessary. Further information may be obtained from OSHA's general requirements section of their Eye and Face Protection Standard (29 CFR § 1910.133).

Protective eye/face devices purchased after July 5, 1994, must comply with ANSI Z87.1-1989. If purchased on or before July 5, 1994, protective devices should at least comply with ANSI Z87.1-1968.

Exposure Monitoring

A number of methods are available for monitoring employee exposures to 1,3-butadiene. The following information addresses some of these methods. Please note that this section is not intended to be a complete review and evaluation of 1,3-butadiene sampling and analytical methods. The employer is responsible for assuring the accuracy and precision of a method relevant to the unique conditions of the specific workplace, no matter which method is chosen. For more information contact your supplier.

Charcoal Tube Methods

Most of the exposure monitoring methods for butadiene involve the use of charcoal tubes with sampling pumps, followed by analysis of the samples using gas chromatography (GC). Differences between methods may include: treated or untreated charcoal tubes; sampling rates; the use of different desorbing solvents; and variations in analytical equipment.

Both OSHA Method No. 56, which is located in Appendix D of OSHA's 1,3-Butadiene Standard, and NIOSH Method 1024 are charcoal tube methods specifically designed for butadiene monitoring.

Passive Monitors

Passive dosimeter badges are available for monitoring airborne concentrations of butadiene. These badges often involve the diffusion of air across a barrier film where the butadiene collects onto a charcoal sorbent. It is desorbed with a solvent and then analyzed by methods similar to that described for charcoal tubes. For information regarding the use of these badges for monitoring butadiene, including potential limitations, contact the badge manufacturer.

A second type of passive monitoring device available for butadiene sampling is a passive diffusion tube. This is a colorimetric method whereby the butadiene

⁵Chemical Protective Clothing, 2nd Edition, American Industrial Hygienist Association, 2003.

⁶Quick Selection Guide to Chemical Protective Clothing, 5th Edition, Forsberg, K., Van den Borre, A., Henry, N., and J. Zeigler

⁷Permeation Guide for DuPont™ Tychem® Protective Fabrics, 2004. http://www2.dupont.com/Personal_Protection/en_US/assets/downloads/tychem/permguid82004.pdf

⁸ASTM F739-12e1, Standard Test Method for Permeation of Liquids and Gases through Protective Clothing Materials under Conditions of Continuous Contact, ASTM International, West Conshohocken, PA, 2012. <http://www.astm.org/cgi-bin/resolver.cgi?F739>

⁹N/A = Not Available

concentration is able to be read directly by the length of the color stain in the pre-calibrated tube. One potential concern with the use of these tubes is that the limit of detection for an 8-hour exposure may be slightly above workplace exposure limits (e.g. OSHA PELs).

Direct Reading, Portable Instruments

There are portable instruments utilizing flame ionization or photoionization detectors that can be used to measure butadiene in low- to sub-ppm concentrations. One potential concern is that these instruments will respond to a wide range of hydrocarbons. As a result, they are non-specific for butadiene and can be affected by the presence of other hydrocarbons.

Detector Tubes

A number of companies manufacture detector tubes for use with volumetric pumps to measure butadiene concentrations. These colorimetric indicating tubes provide a direct reading of the butadiene concentration. A specified amount of air is drawn through the tube, and the butadiene present in the air reacts with the solid sorbent to produce a color change whose length is directly proportional to the butadiene concentration.

A potential concern with the use of these detector tubes is that the limit of detection for these tubes may be slightly above the applicable workplace exposure limits (e.g. OSHA PELs).

Interferences and sampling time are other issues which need to be considered with the use of colorimetric detector tubes. Chemical substances which may interfere with these tubes include carbon monoxide, butane, butylene, ethylene, hydrogen, hydrogen sulfide, propane and propylene. The presence of these chemicals may cause false positive results. With respect to sampling time, current colorimetric tubes require a long sampling period (up to 32 minutes) when analyzing for low levels of butadiene.

Colorimetric detector tubes are therefore not generally appropriate for sampling to confirm compliance with worker exposure limits.

Gas Chromatography (GC)

As noted above, the presence of other hydrocarbons or certain gases may significantly interfere with readings obtained by butadiene detector tubes or other direct-reading hydrocarbon analyzers. Where that occurs, a GC method may be a desirable option. Portable GCs may be taken to the field for direct on-site measurements. Alternatively, a sample of air may be collected in a syringe, bag or summa canister (EPA TL-14 method); the sample can then be injected into a GC for analysis.

Transport of Butadiene

Liquefied butadiene is shipped by pipelines, ships, barges, rail tank cars, tank trucks and bulk liquid containers. Transported butadiene is required to be inhibited and the current industry-wide recognized inhibitor is tertiary butyl catechol (TBC). Also, to minimize the formation of peroxides in butadiene during shipping and handling, the oxygen level in the vapor space of loaded equipment is not to exceed 1000 ppm.

For assistance in any transportation emergency or if a potentially dangerous or problem situation might occur, contact your supplier and/or applicable emergency response agency.

Transport by Rail Tank Cars

Liquefied butadiene is shipped in pressurized rail tank cars. These tank cars are loaded and unloaded from the top and usually can contain about 30,000 gallons of product. The top of the tank car is equipped with a pressure head assembly and protective housing. Table 4.3 lists items mounted on the pressure head assembly.

Table 4.3: Items Mounted on the Pressure Head Assembly

Two Liquid Eduction Valves connected to separate liquid eduction pipes that extend to the bottom of the tank. Either valve may be used to unload product.

A Vapor Line that is used primarily to vent the rail tank car back to the storage tank or a flare. It also can be used to pressure the product out of the rail tank car with compressed product vapors or nitrogen. United States government regulations prohibit the use of air as a pressuring medium.

A Sampling Valve that is used for sampling liquid from the bottom of the rail tank car.

A Safety Valve for flammable gases such as butadiene is typically set at 75 percent of the rail tank car shell test pressure.

A Thermometer Well that is sealed at the bottom and is approximately 60 inches long. It is filled with ethylene glycol for more accurate readings upon insertion of the thermometer.

A Gauging Device which may be either a slip-tube gauging device which extends approximately halfway into the tank and is covered by a protective housing, or a non-venting gauging device. A non-venting gauging device is commonly used, especially for butadiene, and is required by regulations in some jurisdictions.

Feed lines to the liquid eduction valves, the vapor valve and the sampling valve are each fitted with an excess-flow check valve that automatically closes when the product flow rate becomes too high. These check valves are safety devices which help to reduce a product release from accidental opening of the unloading lines or any other part of the unloading system. Also see item 18 under Rail Tank Car Unloading Procedures, below.



Close-up of typical LPG tank car dome, showing liquid and vapor connections and magnetic level gauge.



Typical butadiene rail tank car loading, showing liquid vapor connections. Magnetic gauge stick is visible.

Rail Tank Car Unloading Procedures

Appropriate procedures will help to minimize employee exposure and environmental releases during unloading of butadiene from rail cars. Companies should evaluate the specific circumstances of their rail car unloading facilities to develop appropriate procedures. See Table 4.4 for one example of a rail tank car unloading procedure.

Table 4.4: An Example Rail Tank Car Unloading Procedure

1. Select track or siding that is as level as possible for unloading. Provide protection for the open end of the track or siding, such as a gate, a switch, or a derail.
2. Place regulation caution signs between the rail tank cars and the switch, 25 feet from the rail tank car, if possible.
3. If the siding is open at both ends, place a caution sign at each end. Keep these signs in place until the rail tank car is emptied and disconnected.
4. After the rail tank cars are spotted on the siding, set the hand brakes, chock or block the wheels, and set appropriate flags or approved warning lights at an appropriate place. The flags also are called blue flags and they state either "STOP Men at Work" or "STOP Tank Car Connected." The word STOP is comprised of four (4) inch letters and the rest of the words use two (2) inch white letters on blue background.¹⁰
5. Completely ground and bond rail tank cars and unloading equipment to prevent the risk of explosion due to static electricity accumulation. Safeguards can be installed to prevent the unloading operation from starting until a positive grounding connection has been made using simple electrical circuit safeguards.
6. Keep the rail tank car unloading area clear of any possible ignition sources (permit only explosion-proof electrical apparatus).
7. Rail tank car safety valves should not be tampered with or adjusted by unauthorized personnel. Before starting the unloading operation, check for evidence of tampering with the safety valves or removal of the rail tank car seals. Where evidence of damage or tampering exists, notify the railroad and consult an expert in the rail tank car design and/or operating procedures prior to unloading.
8. Check the rail tank car number, contents and net volume against the bill of lading. Report any rail tank car number, contents or significant net volume discrepancy to the supplier before unloading is begun.
9. For more accurate measurement, before the quantity is gauged, the rail tank car should be stationary for at least 15 minutes.
10. Equip each unloading area with a thermometer attached to a small chain for lowering into the rail tank car's thermometer well.
11. Use the gauging device to determine the liquid level. The total volume of liquefied product in the tank can then be determined from tables supplied by the supplier of the product or the rail tank car owner or builder.
12. **SAFETY CAUTIONS: WORKERS SHOULD NOT PLACE THEIR HEAD OR BODY DIRECTLY OVER THE GAUGING DEVICE AFTER RELEASING THE LOCK BAR. TANK PRESSURE MAY CAUSE THE GAUGE TUBE TO SHOOT UP AND CAUSE INJURY.**

¹⁰ United States, 2010. *Guidelines for the Specification of Blue Safety Flags in Railroad Operations*. Washington, D.C.: U.S. Dept. of Transportation, Federal Railroad Administration.

13. Check that all connections for articulated arms and flexible hoses are tight before opening the isolation valves to start the unloading operation. (Flange-type connections between the rail tank car and the unloading arms and hoses reduce the risk of leakage. Screw-type connections are used by some in the industry. "Quick- disconnect" connections may result in leakage.)
14. **SAFETY CAUTIONS: (1) LIQUEFIED BUTADIENE SHOULD NOT BE PERMITTED TO COME INTO CONTACT WITH SKIN OR CLOTHING. RAPID EVAPORATION WILL CAUSE FREEZING. IF ACCIDENTAL CONTACT OCCURS, AFFECTED AREAS SHOULD BE TREATED AS BURNS. (2) REGULATIONS MAY REQUIRE THE OPERATOR TO WEAR PERSONAL PROTECTIVE EQUIPMENT (PPE) TO AVOID EXPOSURE TO THE PRODUCT VAPORS OR LIQUIDS. (SEE RELATED DISCUSSIONS IN PARTS II, III AND IV OF THIS MANUAL FOR ADDITIONAL INFORMATION.)**
15. Liquefied butadiene may be transported from the rail tank car to storage by pumping or pressuring the product from the rail tank car. For both unloading procedures, maintain a positive pressure in the rail tank car, which can be accomplished by compression using:
 - A compressor located between the pressure storage tank vent line and rail tank car's vapor valve to provide vapor pressure to transfer the product;
 - An inert gas, usually nitrogen, being fed into the rail tank car under pressure through the rail tank car's vapor valve to transfer the product; or,
 - Rail tank car vapor pressure to transfer the product.
16. NOTE: Tank car and storage facility must be bonded and grounded.
17. Unload rail tank cars using one eduction line only. (If both eduction lines are used simultaneously, the excess-flow safety system may not provide protection in the event of accidental opening of the unloading lines or any part of the unloading system.)
18. If too much flow causes an excess-flow check valve to close, close the rail tank car liquid transfer valve. When the sound of the excess-flow valve's opening is heard and after an inspection has been made to ensure the integrity of the unloading system, the rail tank car liquid transfer valve can be slowly reopened. If the procedure just described does not succeed in reopening the excess-flow valve, contact the supplier.
19. During winter, for shipments of product which could contain water in amounts sufficient to freeze and restrict unloading operations, the supplier, with the customer's consent, may add small quantities of antifreeze, such as ethylene glycol or isopropyl alcohol.
20. To keep air out of the rail tank car during handling and return to the supplier, maintain a positive vapor pressure of five psig minimum in the rail tank car at all times.
21. Before returning the rail tank car to the railroad, verify that the rail tank car meets all the regulatory requirements. Notify the supplier of any damage to the rail tank car or any improperly operating rail tank car equipment. Also make the supplier aware of the overall appearance of the tank car, especially if in poor condition.

Transport by Tank Trucks

Tank trucks used for transporting liquefied butadiene are equipped with many of the same safety features found on rail tank cars. A principal difference is that the vapor and liquid education valves usually on tank trucks are located on the bottom of the tank. Tank trucks are often equipped with self-unloading pumps.

The safety precautions to be used for loading and unloading tank trucks are similar to those for rail tank cars. Each user should develop a tank truck unloading procedure based on the site layout and all appropriate regulations or standards.

Transport by Marine Vessels



Butadiene barge loading.

Liquefied butadiene can be transported safely in gas carriers (ships), barges and pressurized containers for ocean, inland waterway, and coastal shipments. Vessels are specially equipped to carry liquefied gases and typically operate in dedicated service, with limited tonnage available on a spot basis. For small quantities, pressurized containers may be used. Vessels and marine facilities shipping butadiene in bulk are regulated by the U.S. Coast Guard. Shipping of butadiene in containers is regulated by the Department of Transportation (DOT).

The product handling facilities used for loading and unloading should be compatible with the vessel design and product operating conditions. Tank barges are typically uninsulated and not equipped for reliquefaction or pumping. Spray loading is

commonly used with tank barges to maximize loading rate and eliminate venting; product is then pressured off with gas or product vapor supplied by the unloading facility. Gas carriers are typically insulated and equipped for reliquefaction and pumping.

Marine shipments must be inhibited and a certificate of inhibition may be required for gas carrier shipments (see 46 CFR § 154.1818 for ships and 46 CFR §§ 151.50-70 for barges). Many of the same precautions identified for rail shipments are applicable to vessel shipments. Inspection of the equipment before a shipment will help ensure that no defects in safety systems, tanks and valves, or loading and unloading systems are present. As with tank cars, loading and unloading should be controlled in such a way to minimize employee exposure and environmental releases.

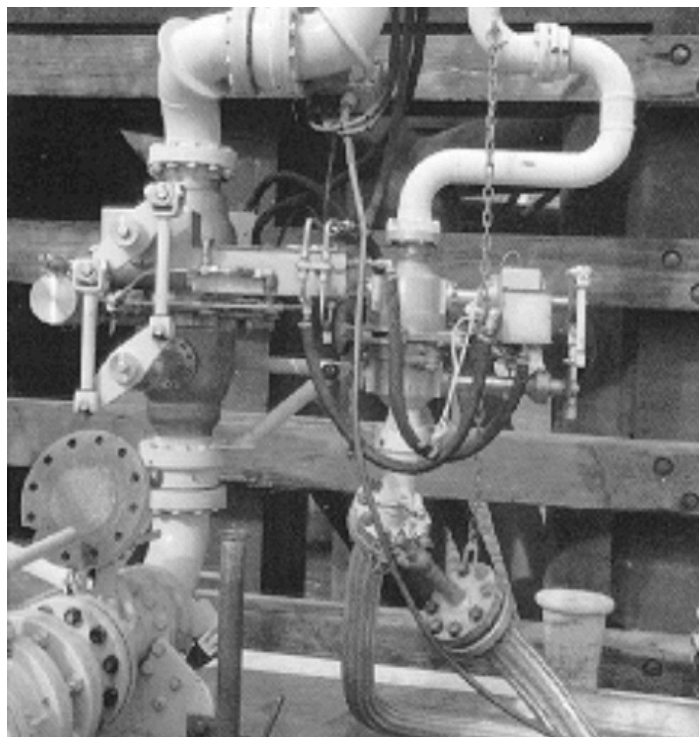

Marine loading arm end fitting, showing emergency isolation and disconnect system. Larger arm is liquid; smaller arm is vapor return.

Transport by Bulk Liquid Containers

Bulk liquid containers or ISO tanks can be shipped by truck, railroad or marine carriers and are used for domestic and export/import shipments of less than tank truck quantities.

Loading, unloading and shipping of butadiene by bulk liquid containers/ISO-containers should be done only after careful review and requires special handling equipment and procedures. Each user should develop an unloading procedure based on the site layout and all appropriate regulations and standards. Consideration of routing and tracking of shipments may be advisable.

Transport by Pipeline

Butadiene is also shipped via pipeline. The DOT regulates the transport by pipeline (see 49 CFR Parts 190-199).

There are a number of measures taken to ensure that the product gets safely to the customer through the pipeline. The primary measure employed is a “line integrity meter.” The pipelines are continuously monitored by control centers that are staffed 24-hours a day. Any discrepancy in terms of the amount entering the pipeline and the amount exiting the pipeline is investigated.

Each operation should have a patrol program to observe surface conditions on or adjacent to the transmission line right-of-way for indications of leaks, construction activity, and other factors affecting safety and operations (see 49 CFR § 192.705). One sign of a leak can be dead vegetation in the immediate area.

The frequency of patrols is determined by the size of the line, the operating pressures, the class, location, terrain, weather, and other relevant factors, but intervals between patrols may not be longer than prescribed by DOT regulations. In certain areas, the frequency of these patrols may be once a week instead of every two weeks.

Methods of patrolling include walking, driving, flying, or other appropriate means of traversing the right-of-way.

Pipeline markers containing the name of the contents of the pipeline and a 24-hour emergency number to call are located at periodic intervals along the pipeline and at all road and stream crossings. If any digging is to be done near the pipelines, notification via the listed number on the pipeline

marker is required. This will enable an individual to be dispatched to identify the exact location of the pipeline.

Cleaning, Inspection & Repair of Transport Equipment

Cleaning, inspection or repair of ships, barges, rail tank cars, tank trucks and bulk liquid containers should be performed by qualified personnel specializing in these operations.

Piping, Fittings and Valves

National codes and standards have been developed for piping and fittings, such as the ANSI B31.3 Code for Pressure Piping. Consider using welds and flanges to join pipe sections, as screwed connections increase the risk of leakage and fugitive emissions from these types of connections. Consider whether the piping and component materials, including valve seats, valve packing and gaskets, are compatible with the chemical that is being handled. For example, packing materials made with polytetrafluoroethylene are not compatible because 1,3-butadiene can absorb and swell the packing.



Close-up of end of loading arm fittings, showing valving that allows purging prior to disconnecting, threaded fitting for connection to tank car valve and bonding wire around loading arm swivel joints.

Articulated arms are generally used for loading and unloading of transport equipment. If flexible hoses are utilized, a rating used is that they have a bursting pressure at least equal to five times the vapor pressure of the product at 100°F.¹¹

Flexible hoses are a potential source of leaking or failure. The design should consider any potential tension, torsion, bending or other stress that could damage the articulated arm or flexible hose. Rough handling or bending during operation of the articulated arm or flexible hoses can damage these arms and hoses. When not in use, it is important that flexible hoses not be left under pressure. Articulated arms and flexible hoses should be inspected frequently, and upon any evidence of damage, immediately tested and/or replaced.

Flange-type connections between the transport equipment and the unloading arms and hoses reduce the risk of leakage. Screw-type connections are used by some in the industry. Butadiene's vapor pressure can disturb the proper operation of the spring connection in "quick-disconnect" connections.

Gate valves or fire-safe ball valves can be used in this type of service. Soft-seated valves can minimize leakage, but all valves should be rated fire-safe. The fire-safe feature provides metal seat backup for the valve stem seal. Cast iron and non-ferrous

valves or fittings have been noted to be unacceptable in this type of service.¹² To provide for isolation in an emergency, general practice is to locate valves as close to the storage facilities as possible.

Pipelines which can be blocked in by closing isolation valves at each end should be protected from over-pressure. Liquid thermal expansion relief valves can be used to provide this protection. Larger pressure-relief devices may be necessary to protect the pipeline to its design pressure.

Storage of Butadiene

Storage facilities for light hydrocarbons are highly specialized. Competent engineering firms should be employed for their design. The following information and the information shown in "PART IV – Handling, Transport and Storage Information: Handling, Safety, Health and Toxicity Data" and in "Prevention/Control of Undesirable Reactions," represent some of the factors that should be addressed for storage of butadiene. Many factors discussed in this section and in "PART IV – Handling, Transport and Storage Information: Handling, Safety, Health and Toxicity Data" are required by applicable regulations, while other factors represent common industry practices. For additional information, consult your supplier or a competent engineer.

¹¹ ASME B31.3-2016. Process Piping.

¹² Ibid.

Storage System Design and Operations

Table 4.5 lists items to consider in developing a storage system for butadiene.

Table 4.5: Items to Consider in Developing a Storage System for Butadiene

1. Carefully select the site, giving consideration to property lines, buildings, adjacent operations and possible sources of ignition.
2. Verify that all vessels to be used for the storage and handling of liquefied diolefins meet recognized code requirements, such as the ASME Code for Unfired Pressure Vessels, or API Standard 620 of Recommended Rules for the Design and Construction of Large, Welded, Low-Pressure Storage Tanks.
3. Design vessels and pipes to prevent the possibility of brittle fracture. Verified notch-tough carbon steels or alloy steels should be chosen to comply with national code requirements, such as ASME-, API-, or ANSI-required toughness at the minimum possible operating temperature.
4. Verify that supports for vessels are of the quality of solid masonry, concrete or steel. If steel is used, protect against fire exposure.
5. Electrically connect all parts of the storage system to one another and to a common ground in a way that will prevent the accumulation of static electrical charges.
6. Enclose the storage vessel within fire banks capable of retaining 100 percent of the vessel's volume. Verify that there is no opening in the fire bank.
7. Verify that the maximum pressure relief valve setting for a vessel is not greater than the vessel design pressure.
8. Connect pressure relief valves to a burning stack or flare system provided with a positive means of ignition. Consider OSHA and EPA requirements and all other applicable regulations.
9. Use totally enclosed gauging devices.
10. Remove air when new equipment is placed in service, or existing equipment is returned to service after it has been opened for inspection or repair. This can be accomplished by filling the tanks and lines with water, then completely displacing the water with inert gas or with vapors of the liquid product to be stored. A practical alternative is to displace the air by a thorough purging of the equipment directly with inert gas when water is not readily available or it is impractical to use water, such as in freezing conditions or if the vessel is not designed for the weight of the water. Targets for residual oxygen concentrations should be as low as possible. Producers recommend that oxygen concentration does not exceed 1000 ppm before placing equipment back into butadiene service. Please contact your individual supplier for specific requirements. The oxygen removal step can usually be integrated with the pressure testing of the vessel. Your individual supplier should be contacted for specific requirements.

Additional Considerations for Design and Operation of Pressure Storage

In filling any pressure vessel, including sample cylinders, with liquefied butadiene, proper outage or allowance should be maintained to allow for the thermal expansion of the liquid. The percentage of the total capacity of a given container which may be used varies with the specific gravity of the liquid to be stored. If no provision is made for thermal expansion and the temperature rises, there may be liquid leakage through the pressure relief valve and a subsequent fire hazard.

Small portable containers and sample cylinders containing hydrocarbons such as 1,3-butadiene should be stored and handled outdoors or in properly constructed and ventilated indoor facilities. The storage or handling site should not be near any sources of heat or ignition, such as steam pipes. Any electrical equipment nearby should be explosion-proof.

Additional Considerations for Design and Operation of Refrigerated Storage

Refrigerated storage tanks can be designed for operating pressures as low as one (1) psig, while spheres, spheroids and bullets may be used for storage at higher pressures.

In order to maintain low vapor pressures, the stored liquefied product normally is cooled by auto-refrigeration or an external refrigeration unit.

Single-wall refrigerated tanks have the insulation attached to the outside of the tank. Double-wall tanks, used for low-boiling hydrocarbons such as propylene, have the insulation between the two walls. The outer wall of double tanks usually is not designed for the containment of any liquid.

The insulation used to fill the between-walls space should be a non-combustible material that resists absorption of liquid hydrocarbon.

The area between the two walls contains hydrocarbon vapor or nitrogen, depending on the design of the storage vessel. If nitrogen is provided between the two walls, the minimum pressure

should be kept above atmospheric pressure to reduce the possibility of a leak.

Both inner and/or outer tanks should be protected against over-pressure, under-pressure and over-filling by means such as a reliable level-indicating device, an independent high-level alarm and a high-level cutoff.

In the case of power failure, all electrical pumps and compressors stop. The pressure buildup due to heat transfer into the vessel while the compressor is shut down should ordinarily be quite small. If made necessary by an extended power failure, however, vapors from the tank should be incinerated as described in Table 4.5, item 8.

Handling, Safety, Health and Toxicity Data

Butadiene liquid or vapor in high concentrations can potentially result in safety and health risks to workers through immediate or long-term exposure. The safety hazards, the industrial health risks and exposure limits for butadiene are often updated or modified through studies and regulatory changes. Standards frequently vary from country to country.

The flammability and explosion risks of butadiene are widely recognized and well documented. The industrial health and toxicity risks associated with hydrocarbon releases are constantly being evaluated and are therefore subject to change. For more detailed information regarding safety, health and/or toxicity data for 1,3-butadiene, refer to appropriate sections of this manual and your supplier's Safety Data Sheet (SDS) for butadiene.

OSHA regulations (29 CFR § 1910.1200(g)) require all butadiene manufacturers to provide customers with the latest Safety Data Sheet (SDS) for butadiene. The regulations require that the SDS be routinely updated to correspond to recent changes in safety practices, and new environmental regulations, industrial health laws and formal guidelines for worker exposure limits (29 CFR § 1910.1200(g) (5)). The SDS also can be used to notify users of applicable regulations. Users should disseminate such information in accordance with OSHA

regulations to give warning of possible hazards to all appropriate persons.

In general terms, these documents contain physical data on the product, information for safety and emergency situations, recommended procedures for immediate medical treatment, identification of fire and explosion hazards, and current occupational health, exposure and protection guidelines.

Consult the supplier's SDS for specific recommendations on handling 1,3-butadiene under regular operations and in emergencies. Supervisory and operating staff must have access to the SDS and receive training on hazardous chemicals in their work area (29 CFR § 1910.1200(h)).

Safe Handling and Disposal of Samples

Care must be taken in the handling and disposal of laboratory-sized and larger samples of diolefins. The potential for peroxide formation exists, even in small quantities of butadiene, and the risks increase with time (See "Butadiene Peroxide Formation" section). Laboratory and sample storage facilities should be appropriate for the associated risks. Test and handling procedures should be clear and the laboratory and operating personnel well trained.

Samples should not be stored at ambient temperatures for periods of more than two weeks, after which peroxide formation may reach dangerous levels (see "Butadiene Peroxide Formation" section). A safe method for in-plant disposal is controlled incineration, at a remote site and with remote control of the ignition source to protect personnel and property. The presence of peroxides increases the potential for an explosion.

Where disposal of large quantities is involved, a competent specialist should be consulted. There are several chemical disposal companies specializing in the safe transportation and disposal of hazardous materials. These companies have the proper equipment and trained personnel to handle the disposal safely.

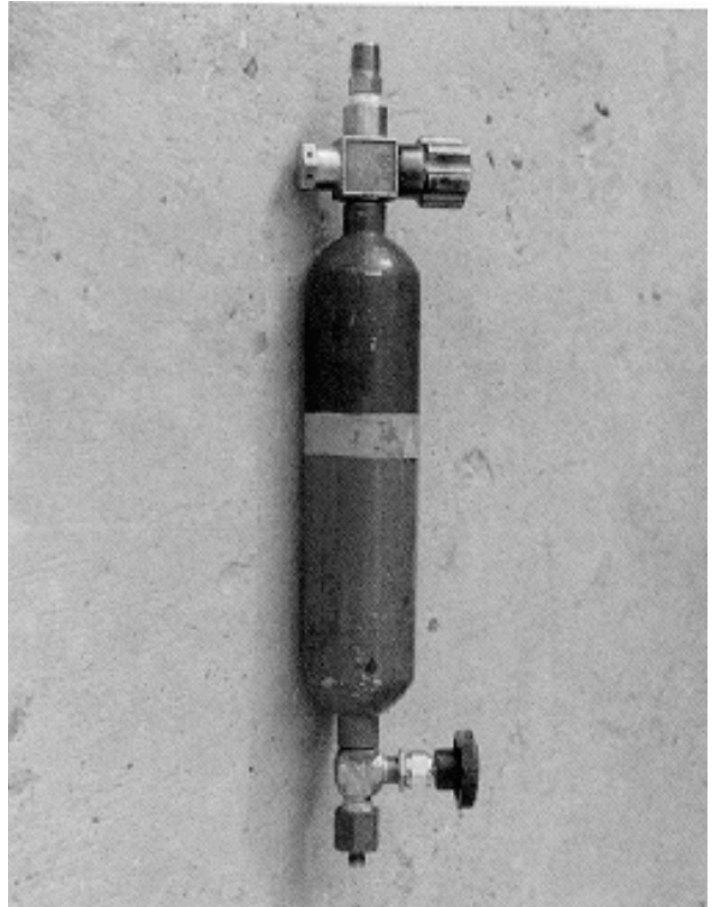

Typical 300cc sample cylinder used for butadiene.

Emission Sources and Controls

Butadiene is normally stored under pressure as a liquefied or compressed gas. It is transported by railroad in tank cars, by roadway in tank trucks, and by water in barges and ocean vessels. Butadiene may be released during manufacture, storage, and use due to process vents, coupling and decoupling activities, mechanical failure of a pump seal, valve pack, pipe connection, or gasket. These (fugitive) emissions are the most common form of industrial release. Releases of this type are regulated and controlled by federal and state rules as well as operating permits. The applicable regulations require frequent monitoring and repair of leaking components within a specified period of time. Butadiene may leak from piping at points where the integrity of pipeline sealing is compromised. Such losses can be minimized by the use of suitable packing materials and pump sealing technology. Butadiene emission reduction activities that have been planned, completed or are in progress at some

sites include those listed below. These are provided as examples of the various ways that butadiene releases can be further reduced. More aggressive fugitive emission monitoring programs can include:

- Leak detection and repair (LDAR) program for valves, pumps and flanges.
- Pump seal replacement (design changed to double seals).
- Analyzer replacement (fewer connections).
- Analyzer vents to closed systems (flare).
- Rupture disks under relief valves.
- Equipment safeguarding (process changes to better control pressure).
- Closed gauging on tanks, barges, rail cars.
- Closed loop sampling systems.
- Reduced butadiene flaring via improved source control (flares are not 100% efficient combustors of butadiene).

Prevention/Control of Undesired Reactions

There are several undesired reactions involving 1,3-butadiene that can occur during manufacture, storage, handling, distribution and use. This section will address:

- Butadiene peroxide formation;
- Popcorn polymer formation;
- Rubber (or plastic) polymer formation;
- Dimerization;
- Reaction from butadiene overcharge; and
- Butadiene incompatibilities.

Butadiene Peroxide Formation

Butadiene and oxygen readily react to form thermally unstable butadiene peroxide. (The

oxygen source can be either air or oxidizing agents.) Butadiene peroxides are extremely dangerous, particularly when concentrated and heated.

Butadiene peroxide is comprised of C₄H₆- and oxygen (-O-O-) units. This material is a viscous, oily liquid that is heavier (denser) than liquid butadiene. These peroxides are explosive, sensitive to heat and can initiate rapid polymerization. When concentrated, a fire or explosion can occur as a result of attaining a critical mass of these peroxides. Mechanical shock can also result in the explosive decomposition of these peroxides.

The peroxide is only slightly soluble in liquid butadiene, and can drop out and form a second liquid phase under the liquid butadiene. They have a solubility limit in butadiene in the range of 120-125 ppm but the solubility is dependent on the molecular weight of the peroxides. As the peroxides age, the molecular weight tends to increase and the solubility in butadiene tends to decrease. Also, as they phase separate from the butadiene, the peroxides tend to accumulate in process low-spots since they are denser and only slightly soluble in the liquid butadiene. As a result, analysis of peroxides in the butadiene phase will not account for those peroxides that have already phase separated and collected in low spots in the storage/piping network.

Butadiene peroxide is believed to play a primary role in the formation of butadiene popcorn polymer. Once this material starts to form, the polymer can continue to build up until it exerts enough mechanical pressure to rupture equipment. Butadiene peroxide can also catalyze the formation of rubber (plastic) polymer. Such polymers tend to lay down on column trays or heat transfer surfaces, causing premature shutdowns for cleaning. (Popcorn and rubber polymers are addressed in detail below.)

Prevention/Control: Peroxide formation is prevented by the exclusion of air (oxygen) from process equipment, pipelines, storage tanks, rail cars, tank trucks, etc. Additionally, inhibitors such as tertiary butyl catechol (TBC) and diethylhydroxylamine (DEHA) are used to scavenge oxygen and free radicals that are formed, for

example, as a result of the peroxide decomposition reaction. Proprietary inhibitors for oxygen and free radical scavenging sold by specialty chemical companies are also available.

Typical TBC concentrations for tank trucks, rail cars, barges and ocean ships are in the 25-150 ppm range and 10-30 ppm TBC for pipeline movements. Since TBC is consumed in the inhibition reaction, periodic analysis for peroxide and inhibitor concentration is conducted.

Many inhibitors protect only the liquefied butadiene in which they are dissolved; TBC is effective only in the liquid phase due to its low volatility relative to butadiene. The TBC/free radical reaction does not seem to be temperature dependent. Low-volatility inhibitors have no influence on butadiene in contact with oxygen in the vapor phase. Therefore, oxygen in the vapor space of storage and transport vessels should be minimized. Typical industry specifications are for the oxygen content in the vapor space not to exceed 0.1%v and the peroxide level in the liquid phase not to exceed 5 ppmw (see Table 1.5).

Equipment design that minimizes low spots in the process will reduce the risk associated with phase separation and accumulation of butadiene peroxides. When low spots cannot be avoided, installation of low point bleeds can facilitate phase rejection. Lines and equipment in butadiene service are cleaned and inspected during regular maintenance cycles.

In general, dead legs and infrequently used lines should be avoided. Piping should be routinely inspected for popcorn polymer plugging.

How to manage popcorn polymer in a unit is a highly technical question entirely dependent on the conditions of the facility and will vary from process to process. Facility-specific process safety documents should be consulted and/or developed and implemented to prevent and control popcorn polymer formation.

Should peroxides be detected in a butadiene storage vessel, additional inhibitor can be added to counteract them and reduce the growth rate. Strong caustic solutions will destroy peroxides; however, the caustic will react with any TBC and form a salt which will render it ineffective.

Additional Considerations for Tertiary Butyl Catechol (TBC) Use: TBC is typically used as an inhibitor for butadiene.

TBC will plate out and form a film on new or clean storage or transport vessels. After a film is formed, very little TBC will plate out in this manner. TBC can also react with iron rust to form a purple TBC-Iron complex which will also deactivate the TBC.

As oxygen in the liquefied butadiene converts to peroxides, and the peroxides break apart to form free radicals, the TBC reacts to scavenge these free radicals.

The TBC-free radical reaction does not seem to be temperature-dependent, and therefore temperature is not thought to be an important factor regarding TBC consumption. However, at cold temperatures there is greater risk of condensation of product vapors in closed vessels, creating a vacuum, which would increase the risk of oxygen intrusion into the system.

Many improvements in the use of TBC have been made over the past five to ten years, such as:

- TBC is stored under a nitrogen blanket in stainless steel containers to maintain its activity.
- The accuracy of the tests for oxygen, TBC and peroxides all have been improved.
- Improvements in equipment and procedures have increased control of the quantity of TBC added to the product.
- Oxygen in the vapor space of tanks and transportation equipment has been reduced significantly.

Approximately five (5) ppmw of TBC is required to neutralize the peroxide formed by one (1) ppmw oxygen.

Additional inhibitor may be required during storage or transport, depending upon length of storage period, frequency of contact with air, and other factors.

Considering these factors, butadiene inventories should be analyzed for the quantities of active inhibitor and peroxide present in solution, and oxygen in the vapor space. Depleted oxygen may indicate peroxide formation. The frequency of these tests will depend on how often the storage is disturbed (by filling or emptying, for example) and the rate at which the inhibitor is depleted. At present, TBC inhibitor levels may be monitored using the total TBC method, ASTM D 1157. If uninhibited

butadiene is used for any purpose, consider conducting tests for peroxides frequently (e.g., daily).

For rail tank car quantities, consider testing storage tanks once a week at the beginning of operations until a routine test program is formulated to meet local experience and conditions. Consider frequent or continuous monitoring and recording of temperature and pressure in storage tanks.

In the United States and many other countries, regulations require that butadiene be inhibited during shipment. The shipper should ensure compliance with all appropriate regulations.

If necessary for the user's processing, inhibitor(s) may be removed by distillation. TBC may also be removed by caustic washing or by running the butadiene through an alumina bed. Inhibitor-free butadiene should be used at once, before peroxides have a chance to form. If uninhibited butadiene is used, consider conducting tests for peroxides frequently (e.g. daily). Thoroughly clean any equipment which has contained inhibited butadiene periodically to remove accumulated polymer.

The inhibitor will partition into any water "heel" present in a storage tank or vessel, since TBC has an appreciable water solubility. Aqueous TBC solutions are acidic and therefore corrosive. To avoid corrosion, drain the water "bottoms" in the tank routinely. Also consider coating the bottom of the tank with a corrosion-resistant material. Note that this partitioning of TBC removes some of the antioxidant from the butadiene phase. Therefore, the butadiene should be refortified with fresh TBC.

Conditions which result in excessive peroxide and polymer formation may be extremely hazardous. Popcorn polymer can absorb oxygen and form a concentration of active free radicals. Heat generated by the resulting accelerated polymer formation can increase temperatures sufficiently to cause runaway conditions that can result in a fire or explosion. See the section on popcorn polymer for more information.

Monitor all system equipment periodically for the presence of peroxides. Where an accumulation of peroxides is known or suspected to exist, contact your

supplier for assistance in addressing this situation. Proper safety precautions should be taken when addressing known or suspected situations involving butadiene and peroxides. An example of a method for addressing an accumulation of peroxides is:

1. Use an aromatic naphtha or solvent, containing an inhibitor such as TBC, to dissolve and dilute the concentrated peroxides. Diluted solutions of peroxide polymers are quite stable.
2. Withdraw and dispose of the hydrocarbon plus the dissolved peroxides, preferably by incineration.
3. Flush the vessel or equipment with a second portion of the hydrocarbon solvent, followed by complete filling with water, which is then heated gradually to 180°F. Note that a caustic water solution is more effective in destroying the peroxide, but prior to employing a basic solution a review of metallurgical compatibility with base solutions should be conducted.
4. Following this procedure, the equipment may be steamed out.
5. **SAFETY CAUTION: Direct steam heating of a vessel or piping is not recommended if there is any possibility that peroxides are still present.**

Butadiene Popcorn Polymer Formation

Conjugated dienes like 1,3-butadiene, isoprene and vinyl aromatics such as styrene all can form popcorn polymer. This polymer can be similar in appearance to cauliflower or popcorn, or it can take the form of glassy, friable crystals; fluffy, needle-like crystals; or hard, clear gel. In a confined space, the growth of popcorn polymer can cause sufficient pressure build-up to rupture pipes, condenser shells, valve bodies and other metal parts.

All possible conditions leading to the formation of butadiene popcorn polymer are not well understood, but experience suggests that it is most likely to form in equipment containing high concentrations of butadiene (typically greater than 80%). However, high diene concentration is not necessary for initiation, as popcorn polymer has been found in columns and exchangers in the product fractionation sections of olefins plants where concentrations are typically much lower.

Popcorn polymer is most likely to form in vapor spaces where the concentration of conjugated diene is high. It can, however, also grow in the liquid phase. Popcorn polymer does not need a seed of its own to grow upon. Butadiene popcorn will grow on isoprene popcorn seeds and vice versa, for example.

The oxygen that participates in the formation of popcorn polymer usually comes from air or peroxides. However, rust and water can enable it to

form even in the absence of air. Rust (iron oxides) alone may even have some ability to initiate popcorn polymer in the absence of water. Once formed, popcorn polymer seeds can propagate on their own due to internal stresses which generate new free radical sites within the polymer matrix with which more monomer can then react. Popcorn polymer grows at a rate proportional to its mass (See Figure 4.1). Growth rate is a function of temperature.

Figure 4.1: Growth of Butadiene Popcorn Polymer at 140 °F

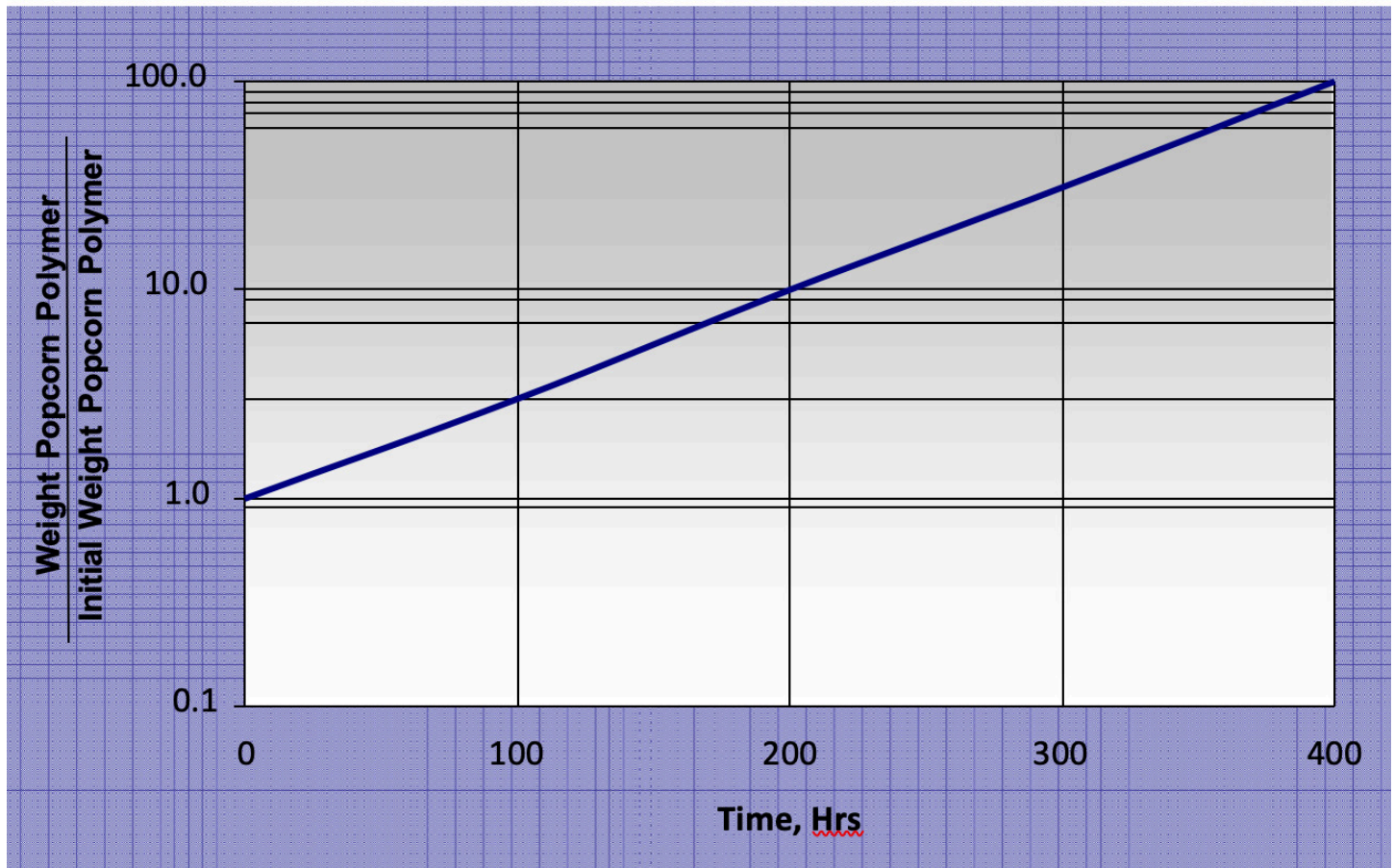

Prevention/Control: Inhibitors such as hydroquinone, tertiary butyl catechol (TBC), certain hydroxylamines, and mercaptans, as well as proprietary inhibitors sold by specialty chemical companies, can be used to reduce the growth rate of popcorn polymer to very low levels. Sodium nitrite has been used to passivate metal surfaces as these surfaces can play a role in popcorn polymer formation. The inhibitors are presumed to react with the free radicals being generated. However, these inhibitors do not permanently deactivate polymerization, for when they are removed, the

polymer seed will eventually attain its former uninhibited growth rate. Also it is important to note that some inhibitors (e.g. TBC) are not volatile enough to protect surfaces in the vapor space.

Popcorn polymer is so reactive that it may autoignite when exposed to air (spontaneous combustion). A common practice to prevent autoignition of air-exposed popcorn polymer is to place the polymer under water to prevent ignition and then incinerate. This reaction is typically observed with popcorn polymer pieces greater than two pounds (1 kilogram) in size.

Thorough removal of popcorn polymer found in equipment will minimize the potential for seeds to initiate further growth when the equipment is returned to service. Popcorn polymer is most often removed by mechanical means, such as chipping or hydroblasting. If the equipment can be safely and conveniently exposed to high temperatures (e.g. heat exchanger bundles), the polymer may be burned off in an oven.

New equipment or equipment being returned to service are purged to remove oxygen (see table 4.5) and can be acid-cleaned and then treated with a hot sodium nitrite solution (see safety notes for sodium nitrite in table 4.7) to remove rust and “passivate” the metal surface in order to reduce the tendency to form diene polymers. Treating with amines will also passivate the metal surface. Advanced passivation procedures sold by specialty chemical companies call for both metal passivation and popcorn seed deactivation at start up. The popcorn seed passivation is conducted with proprietary inhibitors.

Once back in service, adoption of procedures that exclude oxygen from the process will minimize the potential for initiating the growth of new popcorn polymer seeds or forming butadiene peroxides. For example, periodic, controlled venting of all high points in vapor spaces will minimize oxygen accumulation. Other preventive measures include minimizing “dead” vapor spaces, keeping peroxide levels low, and minimizing low points and “dead” legs in the piping systems.

Butadiene Rubber (Plastic) Polymer Formation

This auto-addition product is created by the combination of many butadiene molecules to form a series of high molecular weight molecules. The reaction is accelerated by the presence of peroxides and by increased temperature. In other words, the growth rate of butadiene rubber (plastic) polymer is a function of temperature and peroxide concentration, as illustrated in Figure 4.2.

The polymer may “phase out” due to its low solubility in butadiene and can cause difficulties during process operations. It can coat surfaces in hotter sections of the plant where butadiene concentrations are highest. This polymer can also plug reboiler tubes, foul trays, plug downcomers in columns and coat pump impellers. Rubber (plastic) build-up in critical areas can necessitate a shutdown.

Prevention/Control: Maintaining low temperatures during storage and transportation of butadiene, as well as preventing contact with oxygen, can minimize the formation of rubber (plastic) polymer. Minimization of contact with hot (high temperature) surfaces also can minimize polymer formation. The use of inhibitors such as tertiary butyl catechol (TBC) can diminish the formation of rubber (plastic) polymer.

Figure 4.2: Effect of Benzoyl Peroxide and Temperature on Rate of "Rubber" Polymer Formation

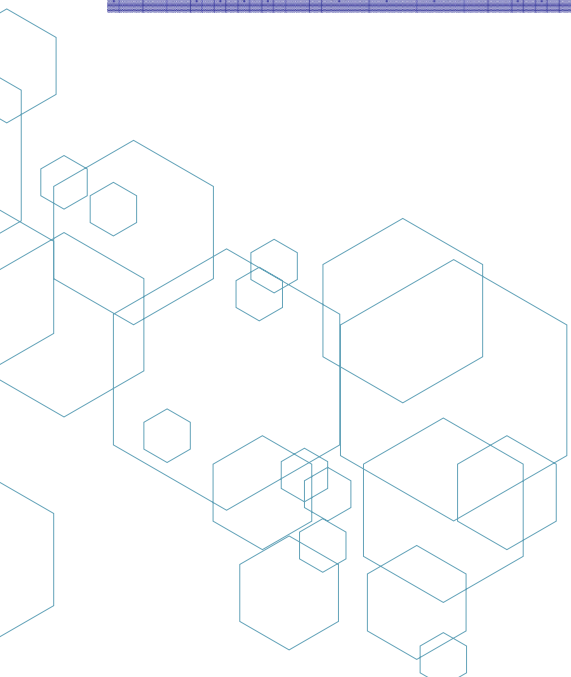
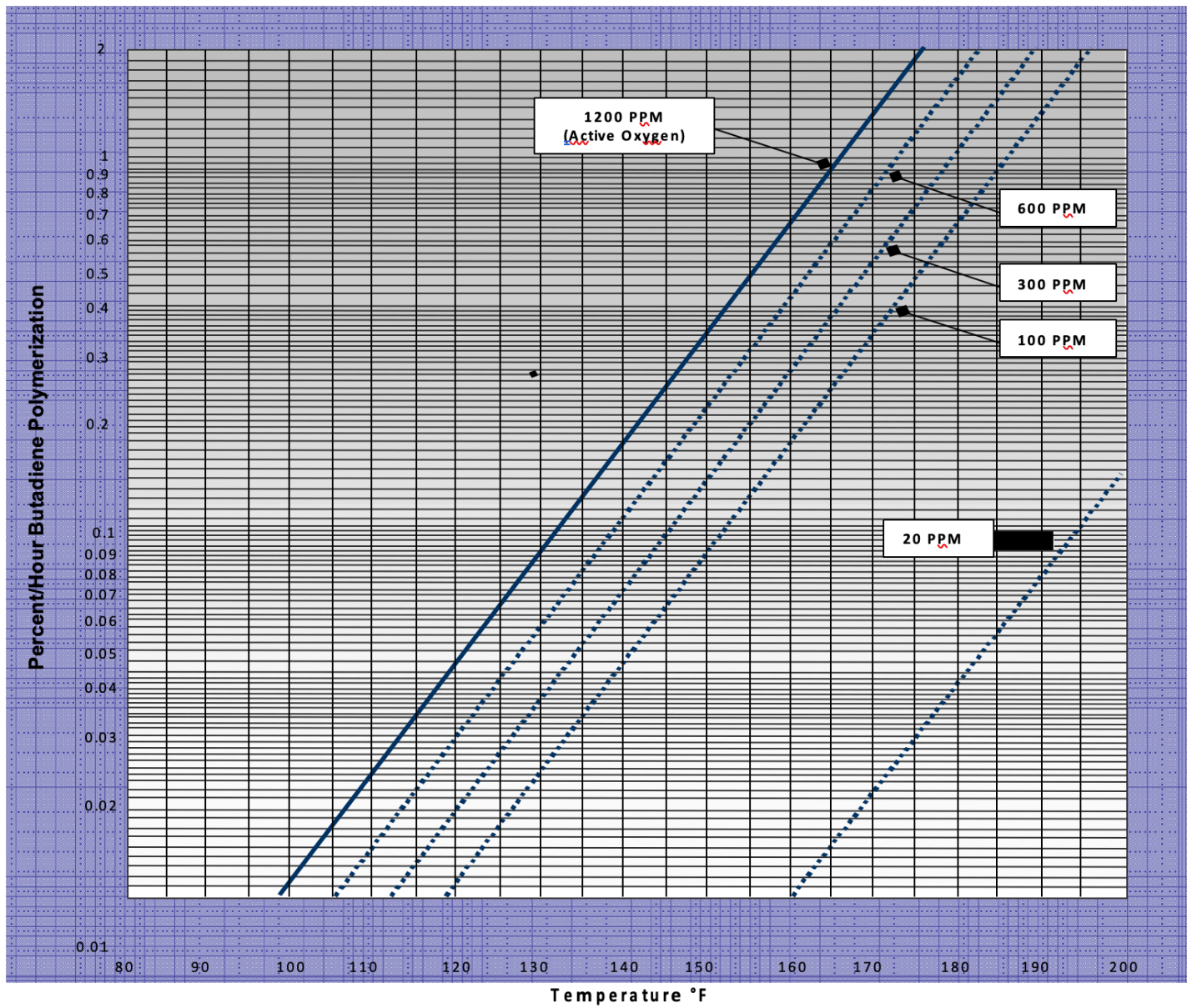

Dimerization

Dimerization of 1,3-butadiene occurs when two butadiene molecules react to form 4-vinylcyclohexene, which also is referred to as 4-VCH. The reaction is a so called Diels-Alder addition (see Figure 4.3). VCH is considered an undesirable contaminant by butadiene consumers. As indicated in the example of a 1,3-butadiene product specification in Table 1.5, there may be consumer requirements to control the dimer level at the time of shipment.

Figure 4.3: Dimerization of 1,3-Butadiene

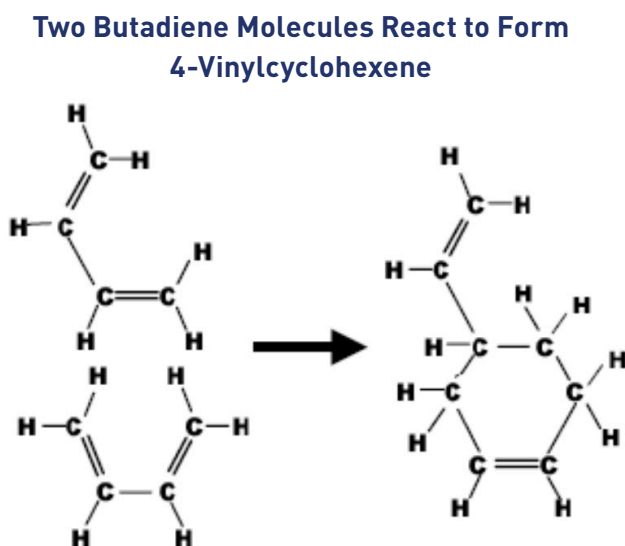

4-VCH is a clear, colorless-to-yellow liquid with a strong, sweet aromatic odor which is very evident at 0.5 ppm. 4-VCH boils at 264°F and has a specific gravity of 0.826 at 77°F. It is miscible in 1,3-butadiene in all proportions where it appears to undergo further polymerization. 4-VCH is classified as a flammable liquid with a flash point of 61°F (closed cup). For health information related to 4-VCH, refer to “PART II – Health and Environmental Effects: 4-Vinylcyclohexene.”.

Dimer (4-VCH) formation is temperature and concentration dependent. The lower the temperature or butadiene concentration, the slower the rate of dimer formation. Conversely, the higher the temperature or concentration, the faster the rate of dimer formation.

Being a Diels-Alder reaction type, the dimer formation is not significantly affected by the

presence of peroxides, either naturally occurring or manually introduced. Nor do steel surfaces affect its formation. At present, there is no known inhibitor for the butadiene dimer reaction. It is strictly a time/temperature/concentration phenomenon. Table 4.6 details what the expected (calculated) formation of butadiene dimer is in weight ppm at various temperatures.

Table 4.6: Effect of Temperature on the Rate of Dimer Formation

Temperature °F	Weight ppm Butadiene Dimerized Per Hour
40	0.3
50.....	0.5
60.....	1.0
70.....	1.8
80.....	3.4
90.....	6.3
100.....	11.8
110	22.0
120.....	41.2
130.....	77.1
140.....	144.4
150.....	270.3

Prevention/Control: To minimize dimer formation, minimize transit and residence/storage times. As illustrated in Table 4.6, storing butadiene at low temperatures will also minimize the amount of dimer formed.

Note, however, that shipping butadiene at low temperatures can have a downside as well. The vapor pressure of butadiene is much lower at lower temperatures, which will increase the potential for oxygen intrusion. Refer to the Butadiene Peroxide Formation section above for additional information regarding the potential impact that oxygen can have on butadiene. Even though the presence of peroxides has no effect on the ratio of dimer formation, it does impact the formation of butadiene popcorn polymer and rubber (plastic) polymer.

Dimer Removal: Currently done via distillation.

Reaction from Butadiene Overcharge

Because of its inherent properties, 1,3-butadiene is used in many polymerization reactions. As suppliers of 1,3-butadiene, the members of the Panel do not have a working knowledge of the chemistry involved in the downstream manufacturing processes utilizing butadiene. Therefore, we cannot predict the precise consequences that could result from abnormal conditions during these reactions. It is very important that each manufacturer perform a process safety review to determine the risks involved and risk management practices to be used in their process.

We are aware of one incident involving a manufacturing process for styrene-butadiene block copolymers. During the manufacture of these products, an explosion and fire were caused by the failure of a reactor vessel due to excessive internal pressure from a runaway chemical reaction in a reactor. This incident occurred in a polymerization reaction where butadiene and styrene were being mixed with a catalyst to form the elastomer products.

Butadiene Incompatibilities

A literature search was conducted to capture the various chemical incompatibilities that have been reported for butadiene. Bretherick's Handbook of Reactive Chemical Hazards 8th Edition, 2017¹³ and the Wiley Guide to Chemical Incompatibilities, 4th Edition, 2009¹⁴ are the primary source for the information in Table 4.7 and below.

If copper (or copper containing alloys),

silver, mercury or magnesium is used during construction or maintenance of vessels that will contain butadiene, the formation of explosive acetylides can occur as a result of contact with the acetylenes in the butadiene. Materials made of polytetrafluoroethylene (PTFE) and polyoxymethylene (POM) may promote popcorn polymer growth.

Fires, explosives or hazardous polymerization may result from contact with strong oxidizers, aluminum tetrahydroborate, chlorine dioxide, crotonaldehyde (explosive reaction >356 degrees/>180 degrees C), strong acids, nitrogen dioxide, ozone, phenol or polymerization initiators such as azobisisobutyronitrile, hydroquinone, or peroxyacetic acid.

Butadiene is an extremely flammable, polymerizable gas: extremely low ignition temperature makes it very dangerous [explosion limits in air (vol%) 2.0 to 11.5; flash point -105 degrees F/-76 degrees C].

Heat can also have a significant impact. An explosion hazard is high if heated under pressure. Solid butadiene at < -171 °F (-113 °C) will absorb enough oxygen at sub-atmospheric pressure to explode violently when allowed to melt.

It is self-reactive, and in absence of an inhibitor (e.g., tert-butyl catechol), autoxidation forms heat-, mechanical shock-, and impact-sensitive peroxides with air.

Flow or agitation of butadiene may generate electrostatic charges due to low conductivity. The uninhibited vapors may form polymers in plug vents, confined spaces, or flame arresters of storage tanks.

¹³ Urben, Peter, ed. Bretherick's Handbook of Reactive Chemical Hazards. Elsevier, 2017.

¹⁴ Pohanish, Richard P., and Stanley A. Greene. Wiley Guide to Chemical Incompatibilities. John Wiley & Sons, 2009.

Table 4.7: Additional Chemical Incompatibilities with Butadiene and Potential Outcome

Chemical	Potential Outcome
Boron fluoride/trifluoride	Violent reaction
Bromine	May cause violent reaction
Carbolic acid	Violent reaction
Chlorine	Forms easily ignited, sensitive, explosive mixture with
Chlorine oxide	Violent reaction
Chlorine peroxide	Violent reaction
Dichlorine	Forms easily ignited, sensitive, explosive mixture with
Hydroxybenzene	Violent reaction
Iodine	Violent reaction
Monohydroxybenzene	Violent reaction
Mononitrogen monoxide	Violent reaction
Nitric oxide	Violent reaction
Nitrogen monoxide	Violent reaction
Nitrous acid, sodium salt	Reaction
Oxybenzene	Violent reaction
Pentachlorophenate	Incompatible
Pentachlorophenol	Incompatible
Phenic acid	Violent reaction
Phenylhydrate	Violent reaction
Phenylic acid	Violent reaction
Sodium nitrate	Violent reaction
Sulfur dioxide	Violent reaction
Sulfurous acid anhydride	Violent reaction
Sulfurous oxide	Violent reaction
Trifluoroboron	Violent reaction

Fire and Explosion Hazard

1,3-Butadiene is a significant fire and explosion hazard based on its physical properties, including flash point, vapor pressure and boiling point. It can quite readily form explosive mixtures in air as a result of its high vapor pressure. Therefore, preventive measures must be taken to minimize the potential for a fire or explosion.

1,3-Butadiene is extremely flammable and is classified as a flammable gas by both the Occupational Safety and Health Administration (OSHA) and the Department of Transportation (DOT). 1,3-Butadiene concentrations in air of between 2.0% and 11.5% can form explosive mixtures. If an ignition source is present, a fire and/or explosion can result. At temperatures of approximately 804 °F or above, this material can autoignite. In other words, it can spontaneously ignite without the application of a flame or spark if it is heated above this temperature.

Vapors of 1,3-butadiene are heavier than air. Thus, 1,3-butadiene vapors may accumulate and travel along the ground a significant distance to an ignition source, resulting in a flash-fire. Liquefied butadiene gas produces a visible fog when it is escaping in a non-fire emergency situation such as a spill or leak. The fog is the result of the liquid vaporization, which condenses water vapor from air. However, the fog is only an

approximate indicator of the amount of butadiene gas in the area. The invisible, ignitable butadiene/air mixture can extend several feet beyond the visible fog area. In a fire situation, conditions can develop which could lead to explosions and further fire propagation. The build-up of pressure in closed containers of butadiene caused by elevated temperatures can result in container failure. When heated under pressure, butadiene may also undergo rapid and uncontrolled polymerization resulting in an explosion.

In addition, the expansion of the liquefied butadiene gas in closed containers that are exposed to fire can lead to a phenomenon called Boiling Liquid Expanding Vapor Explosions (BLEVEs). Liquid butadiene gas is stored under pressure. Therefore, rapid vaporization of a portion of the liquid butadiene gas can occur should the container fail, causing the pressure to be reduced to atmospheric. The result of such a scenario can be a "pressure release explosion," characterized by the extremely quick mixing of butadiene vapor and air, causing a fireball upon ignition by the fire that initially caused the BLEVE.

Fire Prevention

Some general guidelines for fire prevention are included in Table 5.1.

Table 5.1: General Guidelines for Fire Prevention

1. Consider neighboring properties as well as nearby plant operations when locating storage and handling areas. Review all potential sources of ignition.
2. Design and maintain storage and handling equipment in conformance with applicable regulations and codes (ASME, OSHA, API, DOT, National Electrical Code, etc.).
3. Do not permit smoking in areas near where butadiene is stored or handled.
4. Establish stringent hot work practices and systems that fully address butadiene's fire and explosion hazard, including the use of non-sparking tools while working on or near butadiene-containing equipment. (Hot work is defined as including but not limited to welding, cutting and burning.)
5. Employ preventive measures against the accumulation of static electricity. In accordance with applicable codes and regulations, fixed equipment must be grounded. Employ appropriate bonding and grounding during transfer operations.
6. Verify that electrical devices and installations are suitable for Class I, Group B hazardous locations (as defined by Articles 500 and 501 of the National Electrical Code).
7. Verify that storage and handling facilities conform to local ordinances and with the regulations of underwriters and insurance companies.

Fire Fighting

In general, firefighting measures for butadiene are similar to those for liquefied petroleum gases (LPGs). If there is a butadiene fire, or butadiene is located in a fire area, to prevent injury the fire area should be cleared of unauthorized and/or unprotected personnel and isolated. For incidents involving a tank, rail car or tank truck, the Department of Transportation's Emergency Response Guidebook (Guide Number 116) recommends isolating the area for one mile (1600 meters) in all directions. Fire fighters should wear positive pressure self-containing breathing apparatus (SCBA). Structural firefighters' protective clothing will only provide limited protection.

The DOT Emergency Response Guidebook recommends the following procedures when fighting a fire involving butadiene:

- **DO NOT EXTINGUISH A LEAKING GAS FIRE UNLESS LEAK CAN BE STOPPED.**
- Small Fire
 - o Dry chemical or CO₂
- Large Fire
 - o Water spray or fog
 - o Move containers from fire area if you can do it without risk
- Fire involving Tanks
 - o Fight fire from maximum distance or use unmanned hose holders or monitor nozzles
 - o Cool containers with flooding quantities of water until well after fire is out
 - o Do not direct water at source of leak or safety devices; icing may occur
 - o Withdraw immediately in case of rising sound from venting safety devices or discoloration of tank
 - o **ALWAYS** stay away from tanks engulfed in fire
 - o For massive fire, use unmanned hose holders or monitor nozzles; if this is impossible, withdraw from area and let fire burn

¹⁵United States, Canada, and Mexico. 2016. *Emergency response guidebook: a guidebook for first responders during the initial phase of a dangerous goods/hazardous materials incident*. Washington, D.C.: U.S. Dept. of Transportation, Research and Special Programs Administration

If a company opts to fight fires with an internal fire brigade, it must comply with the requirements of OSHA's Fire Brigade Standard (29 CFR § 1910.156). Under these requirements, part of the training provided to the fire brigade members should include information on the hazards of butadiene, quantities present and location(s). Similarly, if a facility utilizes community fire companies for fire response, they should be provided with the same types of information and training as appropriate. In the event of residual butadiene contamination after a fire has been extinguished, the clean-up activities must be conducted in accordance with the requirements of the OSHA Hazardous Waste Operations and Emergency Response (HAZWOPER) standard (29 CFR § 1910.120).

Response to a Leak

During transport, and also during normal plant operations, a release may occur from an accident that damages the container and results in a butadiene leak. Gases or liquefied gases of this type are normally processed in equipment and stored in tanks equipped with pressure relief devices. These devices are designed to release a small amount of the material if the pressure in the tank goes above a preset limit. Use of pressure relief devices greatly reduces the risk of a tank or vessel rupture in the event of a pressure building inside the tank. Use of flares or other control devices to which the relief devices can discharge can reduce the risk of releases to the atmosphere. When released from a tank to the atmosphere, liquid butadiene will become a gas. Due to the storage pressure and low temperature of the material, it can appear like steam. Because it is heavier than air, it will fall to the ground and then mix with the air and seem to disappear. When these releases occur, emergency response measures need to be set in motion as appropriate for the size of the release.

When butadiene is transferred from transport vessels into site storage and distribution pipelines, leakage may occur as a result of butadiene entrapment in the connecting hose and on the atmospheric side of valves. Although purging with nitrogen is partially effective in reducing such loss, substantial butadiene loss may still result. Leaks of butadiene during procedures which result in breaks of containment may be more effectively reduced by the use of dry-break coupling technology.

Sufficient emergency response capability is necessary for responsible management of a hazardous chemical such as butadiene. Preparation in advance of an emergency situation is the most important part of an effective emergency response plan. A thorough plan will cover all possible consequences of a butadiene emergency, including problems that may be specific to a particular site. Effective emergency response plans are generally tested through periodic drills that involve all emergency response personnel both on-site and in the local community. Appropriate response procedures for responding to spills include:

- Remove or shut off all sources of ignition.
- Prevent spill from entering sewers and waterways.
- Wear goggles, respirators, rubber overclothing and gloves.
- Evacuate area in case of large discharge.
- Stay upwind and use water spray to disperse vapors.
- Notify fire department and local health and pollution control agencies.

Also see DOT Emergency Response Guide 116.

APPENDIX A: BUTADIENE MANUFACTURING PROCESS INFORMATION



NOTE

Various processes referred to in this section are licensed; contact the process owner for more information.

Butadiene is produced commercially by three processes:

- **Steam Cracking of Paraffinic Hydrocarbons:** In this process, butadiene is a co-product in the manufacture of ethylene (the ethylene co-product process).
- **Catalytic Dehydrogenation of n-Butane and n-Butene (the Houdry process).**
- **Oxidative Dehydrogenation of n-Butene (the Oxo-D or O-X-D process).**

Each of these processes produces a stream commonly referred to as crude butadiene that is rich in 1,3-butadiene.

Butadiene Production Via Steam Cracking of Paraffinic Hydrocarbons

The steam cracking process is reported to be the predominant method of the three processes of production, accounting for greater than 91% of the world's butadiene supply.¹⁶ Figure A.1 depicts a flow chart for a typical olefins plant. While this does not represent any particular plant, and there are certainly many variations among olefins plants, this representation will provide the reader with a general understanding of the process.

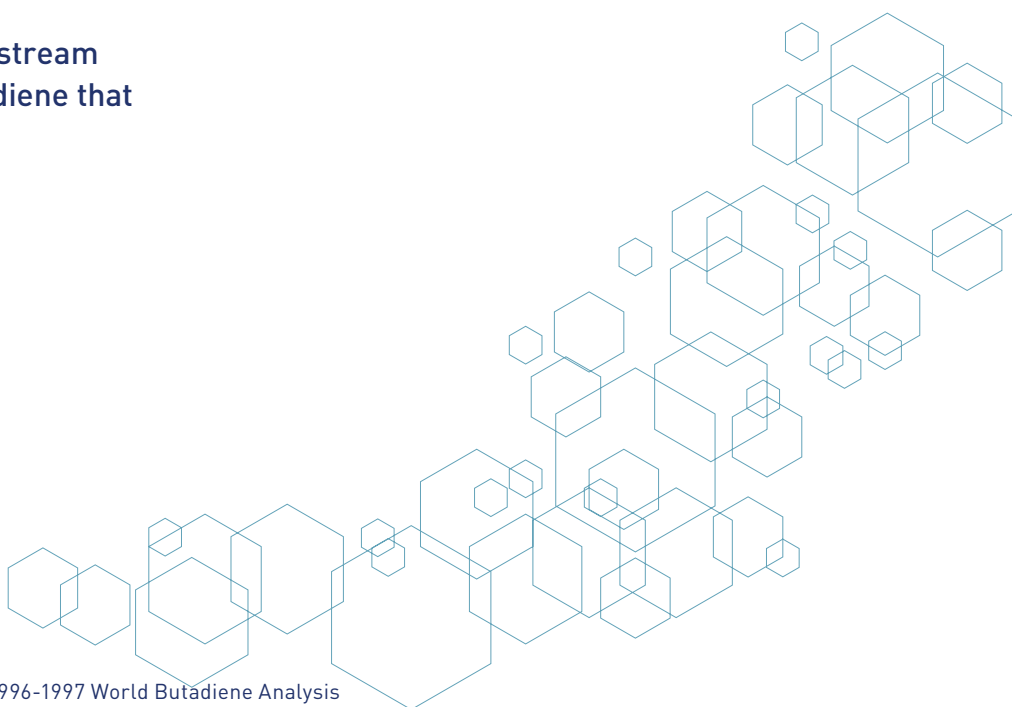

¹⁶ Based on Chemical Market Associates, Inc. (CMAI) 1996-1997 World Butadiene Analysis

when finished butadiene streams (99+ wt% pure) do not meet commercial specifications, they are often combined with crude butadiene streams in order to recover the butadiene. In this situation, the resulting stream may not fall into the example range.

Generally, crude butadiene is stored as a liquid under pressure in a pressure products sphere.

Table A.1: Example of a Crude Butadiene Analysis

Component	Crude Butadiene Vol %	Example Range
C3 & Lighter	0.40	0.01-1.00
i-Butane	1.00	0.50-18.00
n-Butane	5.00	3.00-33.00
Butene-2 (Cis)	4.05	2.50-10.00
Butene-2 (Trans)	5.45	3.50-12.00
Butene-1	14.88	7.00-17.00
i-Butylene	22.50	12.00-27.00
1,2-Butadiene	0.16	0.10-2.00
1,3-Butadiene	44.00	10.00-75.00
C4 Acetylenes	1.41	0.05-3.50
M-Acetylene	0.06	0.01-0.50
E-Acetylene	0.20	0.01-1.00
V-Acetylene	1.15	0.01-2.50
C5+	0.90	0.10-4.00
Other	0.25	100.0

Butadiene Production via Catalytic Dehydrogenation of n-Butane and n-Butene (the Houdry process)¹⁸

The catalytic dehydrogenation of n-butane is a two-step process; initially going from n-butane to n-butenes and then to butadiene. Both steps are endothermic.

A major butane-based process is the Houdry Catadiene process outlined in Figure A.2. In the Houdry process, n-butane is dehydrogenated over chromium/alumina catalysts. The reactors normally operate at 12-15 centimeters Hg absolute pressure and approximately 1100-1260 °F (600-680 °C). Three or more reactors can be used to simulate continuous operation: while the first reactor is on-line, the

second is being regenerated, and the third is being purged prior to regeneration. Residence time for feed in the reactor is approximately 5-15 minutes. As the endothermic reaction proceeds, the temperature of the catalyst bed decreases and a small amount of coke is deposited. In the regeneration cycle, this coke is burned with preheated air, which can supply essentially all of the heat required to bring the reactor up to the desired reaction temperature.

The reactor effluent goes directly to a quench tower, where it is cooled. This stream is compressed before feeding an absorber/stripper system, where a C₄ concentrate is produced to be fed to a butadiene extraction system for the recovery of high purity butadiene.

Figure A.2 Catadiene Process*

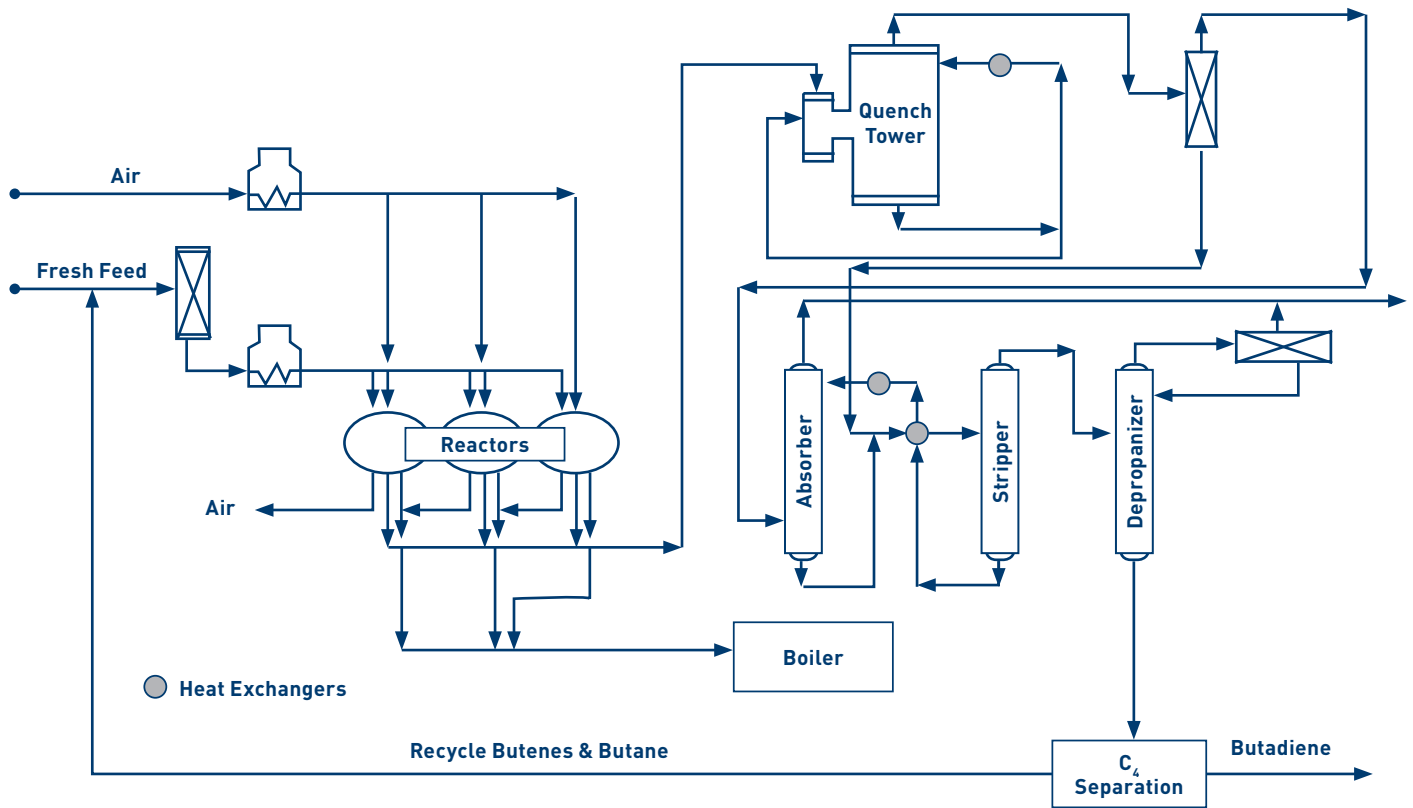

¹⁸Based on Chemical Market Associates, Inc. (CMAI) 1996-1997 World Butadiene Analysis.

Butadiene Production via Oxidative Dehydrogenation of n-Butenes (the Oxo-D or O-X-D process)

Oxidative dehydrogenation of n-butenes has replaced many older processes for commercial (on-purpose) production of butadiene. Several processes and many catalyst systems have been developed for the *oxydehydrogenation* of either n-butane or of n-butene feedstocks. Butenes are much more reactive, however, and they require less severe operating conditions than that of n-butane to produce an equivalent amount of product. Therefore, the use of n-butane as a feedstock in this process may not be practical.

In general, in an oxydehydrogenation process, a mixture of n-butenes, air and steam is passed over a catalyst bed generally at low pressure and approximately 930-1110 °F (500-600 °C). The heat from the exothermic reaction can be removed by circulating molten heat transfer salt, or by using the stream externally for steam generation. An alternate method is to add steam to the feed to act as a heat sink. The heat can then be recovered from the reactor effluent.

Reaction yields and selectives can range from 70-90%, making it unnecessary to recover and recycle feedstock. (Yield losses can produce the CO₂.)

In the Oxo-D process shown in Figure A.3, a mixture of air, steam, and n-butenes is passed over the dehydrogenation catalyst in a continuous process.¹⁹ The air feed rate is such that an oxygen/butene molar ratio of approximately 0.55 is maintained, and the oxygen is totally consumed. A steam to butene ratio of 10:1 has been reported as necessary to absorb the heat of reaction and to limit the temperature rise.

The reactor effluent is cooled and the C₄ components are recovered in an absorber/degasser/stripper column combination. The lean oil flows from the bottom of the stripper back to the absorber, with a small amount passing through a solvent purification area. Crude butadiene is stripped from the oil, recovered in the overhead of the stripper, then it is sent to a purification system to recover the butadiene product.

Figure A.3 Oxo-D Process*

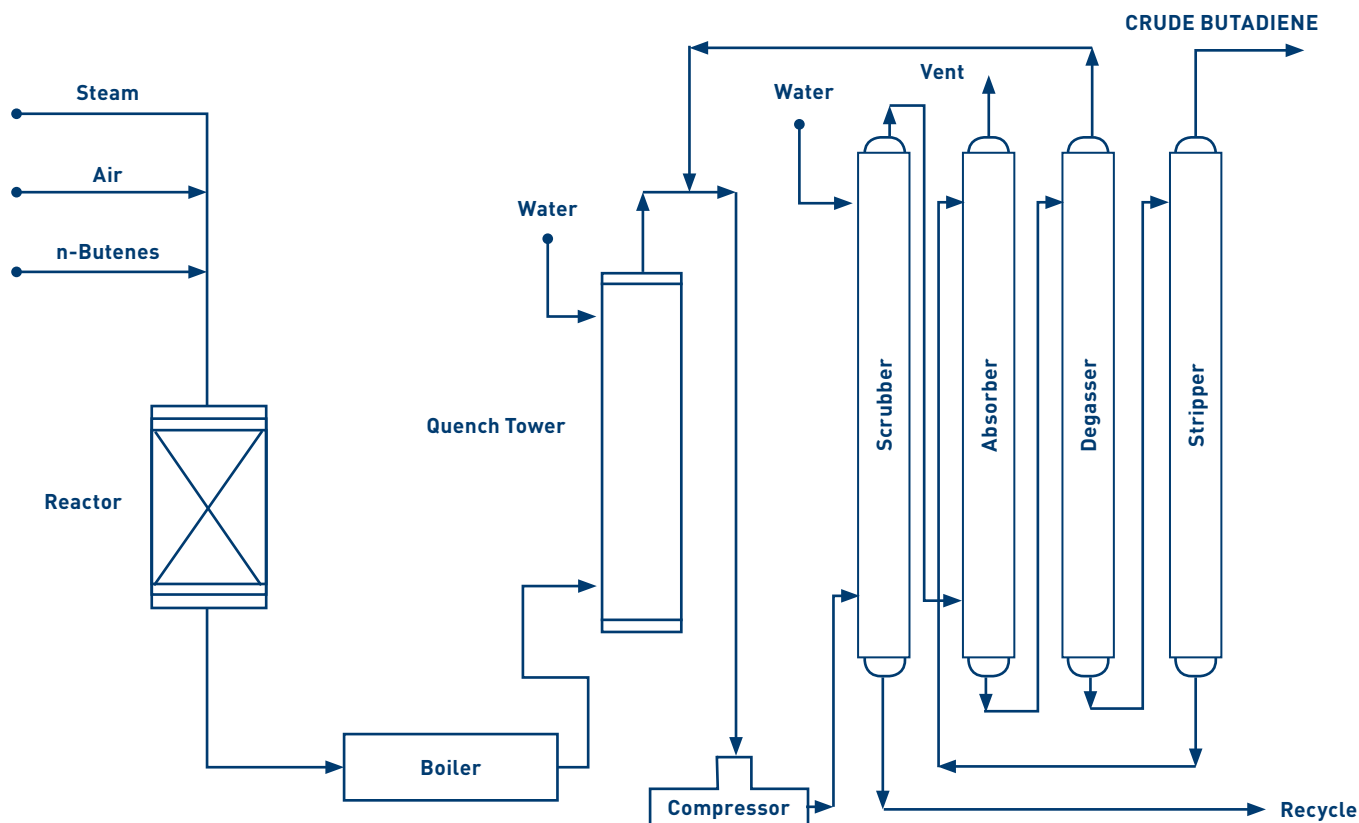

¹⁹ Based on Chemical Market Associates, Inc. (CMAI) 1996-1997 World Butadiene Analysis.

Processing Options for Crude Butadiene Streams

Some processing options for crude butadiene streams are shown in Figure A.4.²⁰ The objective of this Figure is to provide the reader with an understanding of the major downstream processes and markets for the components associated with the crude butadiene stream. It is not an “all inclusive” representation of the marketplace.

Several process options are available for the crude butadiene stream:

- 1) Recycle cracking of the stream in the olefins plant cracking furnaces;
- 2) Hydrogenation followed by recycle cracking;
- 3) Selective hydrogenation of the butadiene to produce an isobutylene/butene-1 rich stream (similar to C₄ raffinate 1);
- 4) Butadiene extraction.

The amount of crude butadiene consumed by each of these four alternatives can depend on crude butadiene supply, available butadiene extraction plant capacity, and demand for the various downstream products. Generally in the U.S., olefins plant crude butadiene streams are processed to isolate 1,3-butadiene for downstream processing. The C₄ raffinate 1 co-product streams generally are fed to either a methyl tertiary butyl ether (MTBE) plant, where the isobutene is converted to MTBE for the oxygenated fuels market, or to a poly-isobutene plant, where the isobutene is polymerized. This leaves the C₄ raffinate 2 components (n-butene/butane mixture) for butene-1 (a co-monomer in the production of linear low density polyethylene), alkylation (motor gasoline octane improvement), and olefins plant feedstock markets.

Figure A.4 C₄ Processing Options*

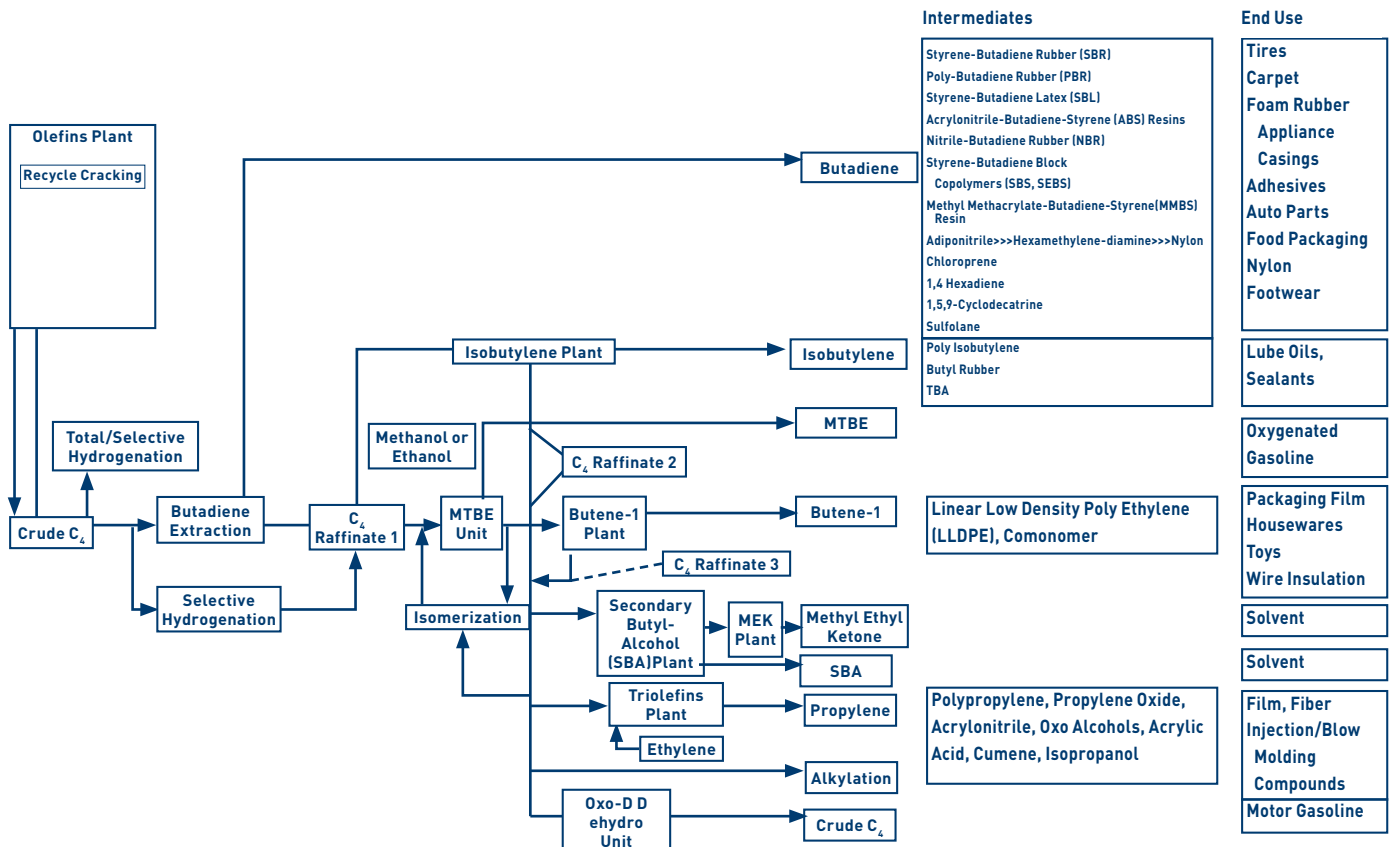

²⁰ Based on Chemical Market Associates, Inc. (CMAI) 1996-1997 World Butadiene Analysis.

Butadiene Recovery from Crude Butadiene Streams Via Extractive Distillation

Since the boiling points of the various C₄ components are so close to each other, separation via simple distillation does not currently suffice to adequately separate the components; therefore, extractive distillation is used. Several design

options are available, including those listed in Table A.2.²¹ Inclusion here is not intended as an endorsement. These processes involve one or two extractive distillation steps followed by one or two distillation steps. The number of extraction and/or distillation steps can be reduced to one by including an acetylene hydrogenation step.

Table A.2: Major Butadiene Recovery Processes

Process	Description (Solvent Used)
Process A	Butadiene Purification via Acetylene Hydrogenation and Extractive Distillation Using Aqueous methoxy-propio-nitrile (MOPN)/ Furfural
Process B	Extractive and Conventional Distillation Process Using Aqueous n-methyl-2-pyrrolidone (NMP)
Process C	Dimethylformamide (DMF) Solvent Extraction Process Using Aqueous n-methyl-2-pyrrolidone (NMP)
Process D	Aqueous Separation and Acetonitrile (ACN) Extraction

Simplified schematics for each process are presented in Figures A.5-A.8.

Figure A.5: Process A - Acetylene Hydrogenation/Extractive Distillation

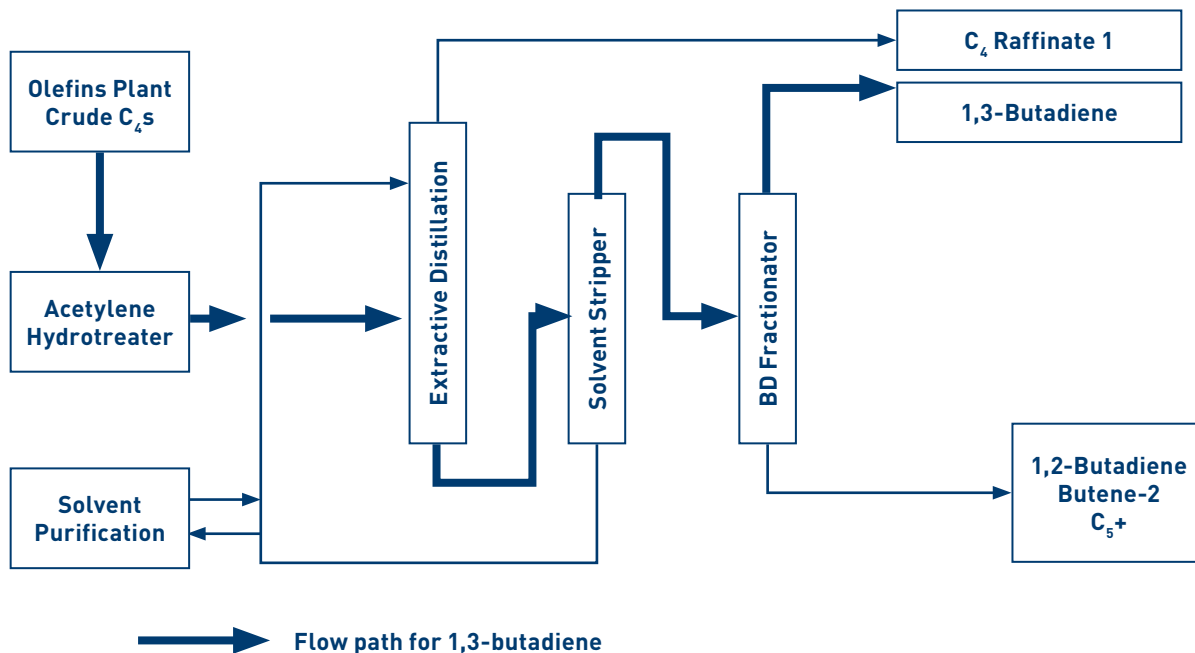

²¹ Based on Chemical Market Associates, Inc. (CMAI) 1996-1997 World Butadiene Analysis.

Process A: Butadiene Purification via Acetylene Hydrogenation and Extractive Distillation Using MOPN/Furfural Solvent

This process contains four sections: 1) acetylene hydrogenation, 2) extractive distillation, 3) butadiene purification, and 4) solvent purification.

The objective of the acetylene hydrogenation section is to hydrogenate C4 acetylenes that could otherwise contaminate the butadiene product. This is achieved using a liquid phase reactor system. Butadiene-dimers and trimers formed in the reactor are removed via distillation in the green oil column located just downstream of the reactor. The green oil column overhead stream is fed to the extractive distillation section.

The function of the extractive distillation section is to separate the C4 hydrocarbon stream into a butane/isobutene/trans-butene-2 stream (C4 Raffinate 1) and a butadiene/cis-butene-2 stream via extractive distillation and solvent stripping. The green oil column overhead stream is vaporized then fed to the lower portion of the extraction column where the vapors are counter-currently contacted with the aqueous methoxypropionitrile (MOPN)/furfural solvent which is fed into the top of the column. Butane and the less soluble butenes are concentrated and removed in the overhead stream. The butadiene/cis-butene-2 rich solvent from the bottom of the extraction column are fed to the extract stripper column, where butadiene, cis-butene-2 and acetylenes (ppm level) are stripped overhead.

The extract stripper column overhead stream is used to feed the butadiene purification column where butadiene is concentrated in the overhead product. Then the remaining butene-2 and heavier components are drawn from the bottom of the column and recycled to the olefins plant cracking furnaces.

The purpose of the solvent purification section is to remove impurities from the lean solvent. The system consists of two evaporators, a stripping column and a solvent settling drum

which are used to remove furfural-butadiene polymer, acrylonitrile-butadiene codimer, and vinylcyclohexene compounds.

Process B: Extractive and Conventional Distillation Process Using NMP Solvent

This process, licensed by BASF and illustrated in Figure A.6, is a combination of extractive and conventional distillation. The extractive distillation uses n-methylpyrrolidone (NMP) as the solvent. The highest temperature is approximately 300°F and the maximum pressure is approximately 100 psig (7 bars g).

The evaporated C4 cut is fed to the extractive distillation section where in the first stage the butanes and the butenes are separated from the more soluble 1,3-butadiene, 1,2-butadiene, C4 acetylenes, propyne and the C5 hydrocarbons.

The loaded solvent is degassed in a steam heated column where the acetylenes are withdrawn as a side stream and are fed to a washer where the NMP is recovered.

Crude butadiene leaves the extractive distillation section at the top of the second stage and is then fed to the propyne distillation column where propyne (methyl-acetylene) is removed overhead. The bottoms product containing the 1,3-butadiene, 1,2-butadiene and the C5 hydrocarbons is then distilled in the butadiene column. Generally, 1,3-butadiene with a purity of >99.6% by weight leaves the top of the butadiene column. The column bottoms stream usually contains 1,2-butadiene and heavier hydrocarbons.

The crude butadiene, the top of the propyne column, and the purified butadiene are typically inhibited with tertiary butyl catechol (TBC) or with other compounds. Sodium nitrite can be used as an inhibitor during extractive distillation.

The excess hydrocarbon streams can be diluted with naphtha and used as supplemental feedstock for the olefins plant.

Figure A.6: Process B - Extractive and Convection Distillation Using NMP

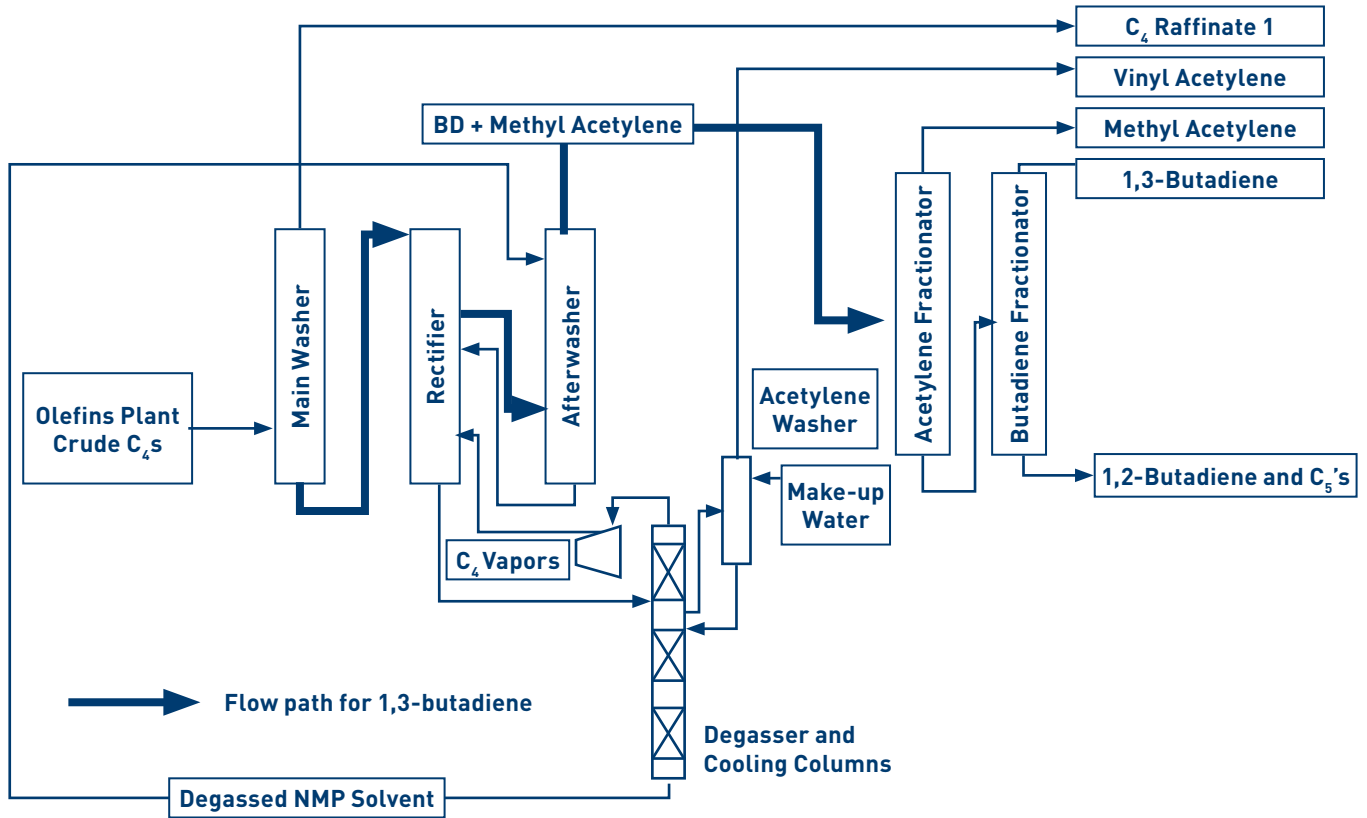
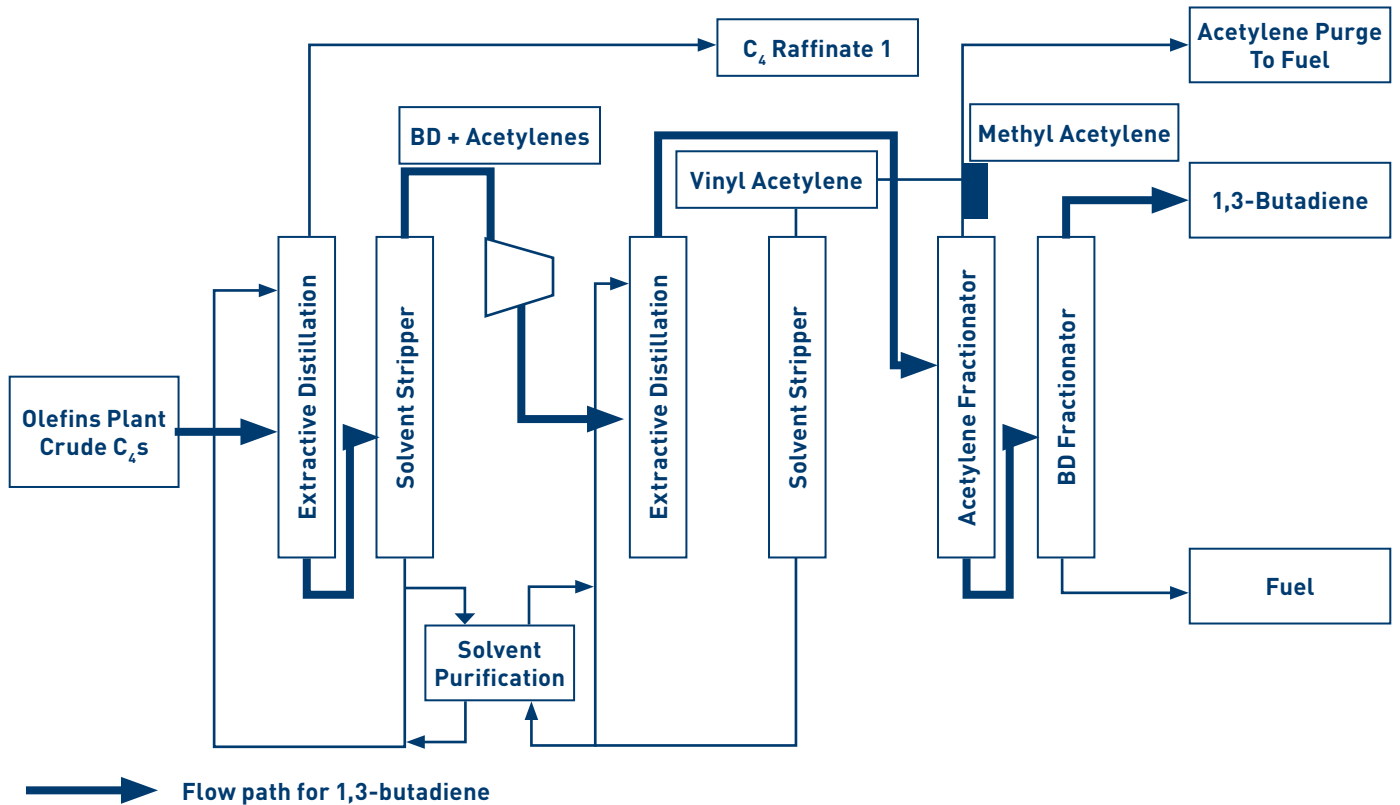

Figure A.7: Process C - DMF Solvent Extraction Process



Process C: Dimethylformamide (DMF) Solvent Extraction Process

This process, licensed by Nippon Zeon, consists of four sections: 1) first extractive distillation; 2) second extractive distillation; 3) butadiene purification; and 4) solvent purification. See Figure A.7.

In the first section of the plant, the hydrocarbon feed (C4 fraction) and the DMF solvent are fed to the first extractive distillation column, where the C4 stream is separated into two fractions:

- 1) the C4 raffinate 1 overhead product, which contains less soluble components (butane/butene); and
- 2) the bottoms product, which contains the DMF solvent rich in butadiene/acetylene components which are the more soluble components.

At this stage, the C4 raffinate 1 product stream is available for downstream processing (MTBE, polyisobutylene, alkylation). The butadiene/acetylene rich solvent is fed to the first stripper column where the butadiene/acetylenes are stripped from the solvent and proceed overhead to the second extractive distillation section. The lean solvent from the stripper is cooled via heat recovery prior to being sent back to the extractor.

In the second extractive distillation section, the butadiene/acetylene stream from the first section also is separated into two fractions, again using DMF as the solvent:

- 1) a butadiene/methyl acetylene rich overhead fraction; and
- 2) a bottoms fraction, containing the DMF solvent rich in vinyl acetylene which is more soluble in the DMF solvent than is butadiene or methyl acetylene.

The butadiene/methyl acetylene rich overhead fraction is sent on to the butadiene purification section of the process where the remaining acetylenes are removed using two distillation columns and a pure 1,3-butadiene product stream is produced. The bottoms fraction from the second extractive distillation is fed to a stripper column where a vinyl acetylene rich stream is stripped from the solvent and used for fuel.

Since the DMF solvent is continuously circulated to the first and second extractive distillation columns, butadiene dimer, tar, and any water from the C4 feed stream tend to increase in concentration, thereby decreasing the effectiveness of the solvent. Therefore a part of the solvent is continuously passed to the solvent purification section of the plant to remove these impurities.

Figure A.8: Process D - Aqueous Separation and ACN Extraction Process

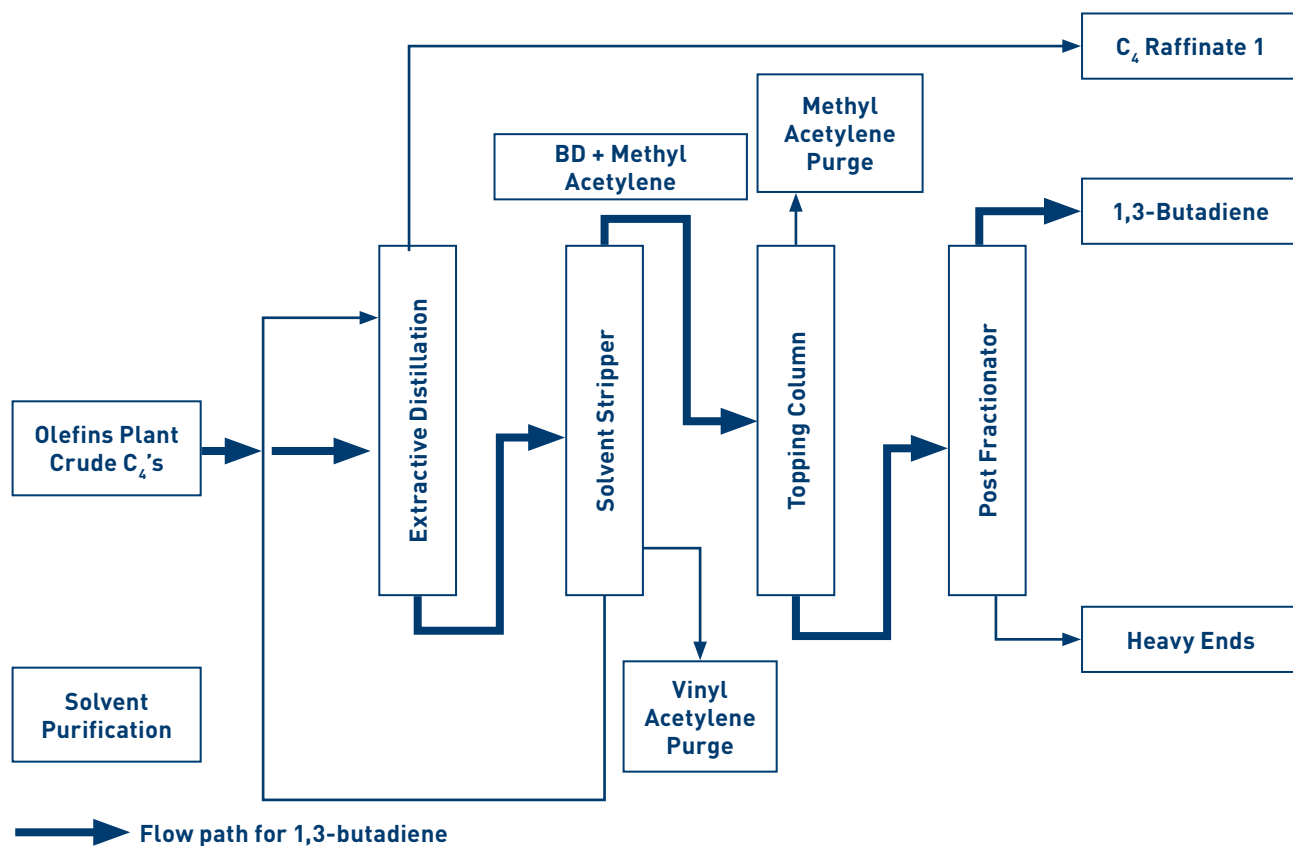

Process D: Aqueous Separation and Acetonitrile (ACN) Extraction

In this process, licensed by Shell and LyondellBasell Industries, the hydrocarbon feed (C4 fraction) is routed to an extractive distillation system. The separation is achieved in an aqueous solvent environment, where the top product contains the butanes/butylenes and the bottoms stream contains the butadiene and acetylenes. Acetonitrile (ACN) is used as the extraction solvent.

As illustrated in Figure A.8, the butadiene is then stripped from the extraction solvent and may be fed to a topping column where residual light ends (primarily methyl acetylene) are rejected. Heavier acetylenes such as vinyl acetylene and ethyl acetylene are rejected as a side stream from the solvent stripping operation. Bottoms product from

the topping column can be fed to a postfractionator where residual olefins (cis-2/trans-2 butene) and remaining trace heavy ends (vinyl, ethyl and heavier acetylenes, 1,2-butadiene, dimer, C5's and heavier) are rejected to the bottoms.

The overhead butadiene product is chilled and passed through a coalescer to remove entrained water before being sent to the rundown tanks in the tank farm. Tertiary butyl catechol (TBC) is added to the butadiene to inhibit the formation of peroxides. It is also common to use an in- process inhibitor that is removed prior to the addition of TBC.

Hydrocarbon streams exiting the process can be washed with water for the removal of ACN. The recovered solvent can be concentrated and returned to the extraction section.

APPENDIX B: INFORMATION ON PRODUCT SAFETY AND RESPONSIBLE CARE®



Purpose and Scope

Chemistry is a source of innovation that creates a healthier, safer and more sustainable future. From solar cells, wind turbines and rechargeable batteries to air filters, water purifiers and disinfectants, chemistry enables us to save energy, reduce pollution and enhance public health.

The American Chemistry Council's (ACC) Responsible Care companies manufacture a broad array of chemical products, ranging from commodity industrial chemicals used to make other chemical products, to specialty chemicals tailored for unique applications and formulations, to finished goods and consumer products. Product safety and stewardship are shared value chain responsibilities, as each company, depending upon its position in the chemical value chain, has a distinct and essential role to play. At each stage in the value chain, protecting public health, safety, and the environment must be embraced as a core value, as it is by chemical manufacturers.

ACC Responsible Care companies are committed to making innovative chemical products that can be used safely for their intended purposes. As part of this commitment, ACC and its members created the Responsible Care Product Safety Code, which sets forth a set of practices to manage chemical product safety as part of our industry's signature health, safety, security, and environmental management system. The Code reinforces Responsible Care's legacy of product stewardship that goes beyond regulatory requirements, which has been a central tenet of the program since its inception.

The Responsible Care Product Safety Code provides a comprehensive framework to drive continuous improvement in chemical product safety and stewardship. Implementation of the Product Safety Code is mandatory for all ACC Responsible Care companies.

Management Practices

The Product Safety Code requires that companies include product safety and stewardship as part of their management systems. Product safety management requires an understanding of intended product uses, a science-based assessment of potential risks from products, and consideration of the opportunities to manage product safety along the value chain. A key component of managing product safety by parties in the value chain is exchanging information regarding product hazards, intended uses, handling practices, exposures and risks. Product stewardship is the responsibility to understand, manage and communicate the health and environmental impacts of chemical products.

Taken together, implementation of the following management practices enables chemical manufacturers to systematically evaluate, demonstrate and continuously improve their product safety performance, while also enhancing communication about important factors that can influence product safety throughout the value chain.

Guiding Principles for Responsible Care®

Chemistry is essential to the products and services that help make our lives safer, healthier and better. Through the Responsible Care initiative and the Responsible Care Global Charter our industry has made a worldwide commitment to improve our environmental, health, safety and security performance. Accordingly, we believe and subscribe to the following principles:

To lead our companies in ethical ways that increasingly benefit society, the economy and the environment.

To design and develop products that can be manufactured, transported, used and disposed of or recycled safely.

To work with customers, carriers, suppliers, distributors and contractors to foster the safe and secure use, transport and disposal of chemicals and provide hazard and risk information that can be accessed and applied in their operations and products.

To design and operate our facilities in a safe, secure and environmentally sound manner.

To instill a culture throughout all levels of our organizations to continually identify, reduce and manage process safety risks.

To promote pollution prevention, minimization of waste and conservation of energy and other critical resources at every stage of the life cycle of our products.

To cooperate with governments at all levels and organizations in the development of effective and efficient safety, health, environmental and security laws, regulations and standards.

To support education and research on the health, safety, environmental effects and security of our products and processes.

To communicate product, service and process risks to our stakeholders and listen to and consider their perspectives.

To make continual progress towards our goal of no

accidents, injuries or harm to human health and the environment from our products and operations and openly report our health, safety, environmental and security performance.

To seek continual improvement in our integrated Responsible Care Management System® to address environmental, health, safety and security performance.

To promote Responsible Care® by encouraging and assisting others to adhere to these Guiding Principles.

Product Safety Code of Management Practices

Each Responsible Care company's management system will include the following product safety and stewardship management practices:

Leadership commitment. Senior leadership commitment to a culture of product safety and stewardship. Each company's senior leadership demonstrates clear commitment through their words, policies and actions throughout their organization and in external communications.

Senior leaders drive continuous improvement of product safety and stewardship through published policies, active participation and communication concerning product safety, establishing, tracking/reporting of objectives and goals, and providing sufficient and qualified resources. Senior leadership is charged with evaluating the effectiveness of product safety programs and providing active support to drive improvement.

Accountability and management. Clearly established organizational accountability for product safety and stewardship. Product safety and stewardship are integral to business processes and employee expectations.

Product safety and stewardship are core values that permeate each company's operations and functional responsibilities. Product safety and stewardship responsibilities of employees are understood,

including those roles that engage with suppliers, customers, contract manufacturers, carriers, distributors, contractors and third-party logistics providers. Employees assigned these roles are informed and held accountable for their performance.

Prioritization of products. A risk-based process that considers available hazard and exposure information to prioritize products in need of further evaluation.

Companies have a process in place to prioritize their products to identify those that require a more detailed evaluation, assessment, and risk management controls, as well as those that require additional data and information gathering. Companies apply a science- and risk-based approach, considering hazard, intended uses and exposure potential when they prioritize their products. Companies include criteria that are applied uniformly to all products screened and that incorporate relevant, credible scientific advances and consider significant new information to ensure that prioritization decisions remain current.

Product information. A process to develop and maintain information on safety, health and environmental hazards, intended uses and exposures for new and existing products to support risk characterization and product safety management.

Companies consider the results of their risk-based prioritization process when gathering and developing information that is used in their risk evaluations, characterizations, and consideration of product safety management actions. Companies evaluate existing information and appropriate assessment techniques, such as ACC's science policies and principles, to determine when additional information on hazards, intended uses, and exposures is needed.

Risk characterization. A process for the characterization of product risks based on information collected on hazards, intended uses, and exposures associated with the stages of a product's lifecycle.

Companies characterize the potential risks of their products using an iterative, tiered process that considers prioritization results and may identify needs for additional hazard, use and exposure information. Risk characterizations include consideration of information about downstream uses and reasonably anticipated exposures, including potential exposures to children. Risk characterizations use valid, reliable and relevant scientific studies and information, giving such studies and information appropriate weight, to determine potential risks associated with relevant levels of exposure under expected conditions of use.

Product safety management. A process to identify, implement, document and communicate health, safety and environmental measures to manage risk so that products can be safely used for their intended purposes.

Companies implement a process to select, implement, document and communicate measures that appropriately manage health, safety and environmental risks of their products. A range of measures may be considered commensurate with the risk characterization, taking into account the feasibility of value chain implementation. Examples of such measures may include labeling, handling instructions, training, engineering and design controls, use restrictions and/or reformulations. Risk management actions may require modifications based on substantive new information on hazards, uses and exposures so that products can continue to be safely used for their intended purposes.

Management of new information. A process to identify and evaluate new information that may trigger changes to risk characterizations and product safety management actions. Such triggers include significant new product safety and stewardship information, including hazard, use and exposure information.

Companies establish processes that enable new information to be brought to light and establish when and how to elevate product safety and stewardship

issues within the company. New information could come from internal and external sources.

Product design and improvement. A process that considers health, safety and environmental impacts in the innovation, design, development, and improvement of products, their manufacture, and uses.

Companies consider health, safety and environmental impacts when designing and improving their products, including factors such as intended use, expected product lifetime, durability, reuse, recyclability or beneficial disposition.

Value chain communication, cooperation and outreach.

Processes to work with suppliers, customers and other value chain participants to foster product safety management and information exchange along the value chain, commensurate with risk.

Commensurate with risk, companies work with and as appropriate, review customers, suppliers, contract manufacturers, carriers, distributors, contractors and third-party logistics providers based on Responsible Care or other health, safety, security and environmental performance criteria. Processes are in place to communicate, receive and evaluate product safety and stewardship information and requests from value chain participants. If improper practices involving a product are discovered, corrective measures are taken based upon a company's independent judgment, ranging from resolving the improper practices to termination of business relationships, if necessary.

Information sharing. Publicly available product safety and stewardship information.

Companies make product safety and stewardship information publicly available to enhance public knowledge of and confidence in the safe use of chemical products, while protecting confidential business information. Publicly available information includes relevant health and environmental effects and safety management measures to promote safe handling and use of products throughout their lifecycle.

Performance assessment and continuous

improvement. Routine monitoring and assessment of product safety and stewardship, with processes in place to drive continuous performance improvement and implement corrective actions when needed.

Companies implement an internal process to monitor and assess product safety and stewardship performance, utilizing appropriate indicators. Companies report their activities associated with implementation of this Code to ACC to facilitate public understanding of the industry's overall product safety commitment and performance.

Amoore, J.E., Hautala, E., 1983. Odor as an aid to chemical safety: odor thresholds compared with threshold limit values and volatilities for 214 industrial chemicals in air and water dilution. *Journal of Applied Toxicology*, #272-290.

Daubert, T.E., Danner, R.P., Sibul, H.M., and Stebbins, C.C., DIPPR® Data Compilation of Pure Compound Properties, Project 801 Sponsor Release, January 1994, Design Institute for Physical Property Data, AIChE, New York, NY. Note: Semiannual updates released in January and July.

Hansch, C., Leo, A. *Substituent Constants for Correlation Analysis in Chemistry and Biology*. New York, NY: John Wiley and Sons, 1979, p.183.

Verschuereen, K., *Handbook of Environmental Data of Organic Chemicals*, 2nd edition, New York, NY: Van Nostrand Reinhold Co., 1983, P. 296.

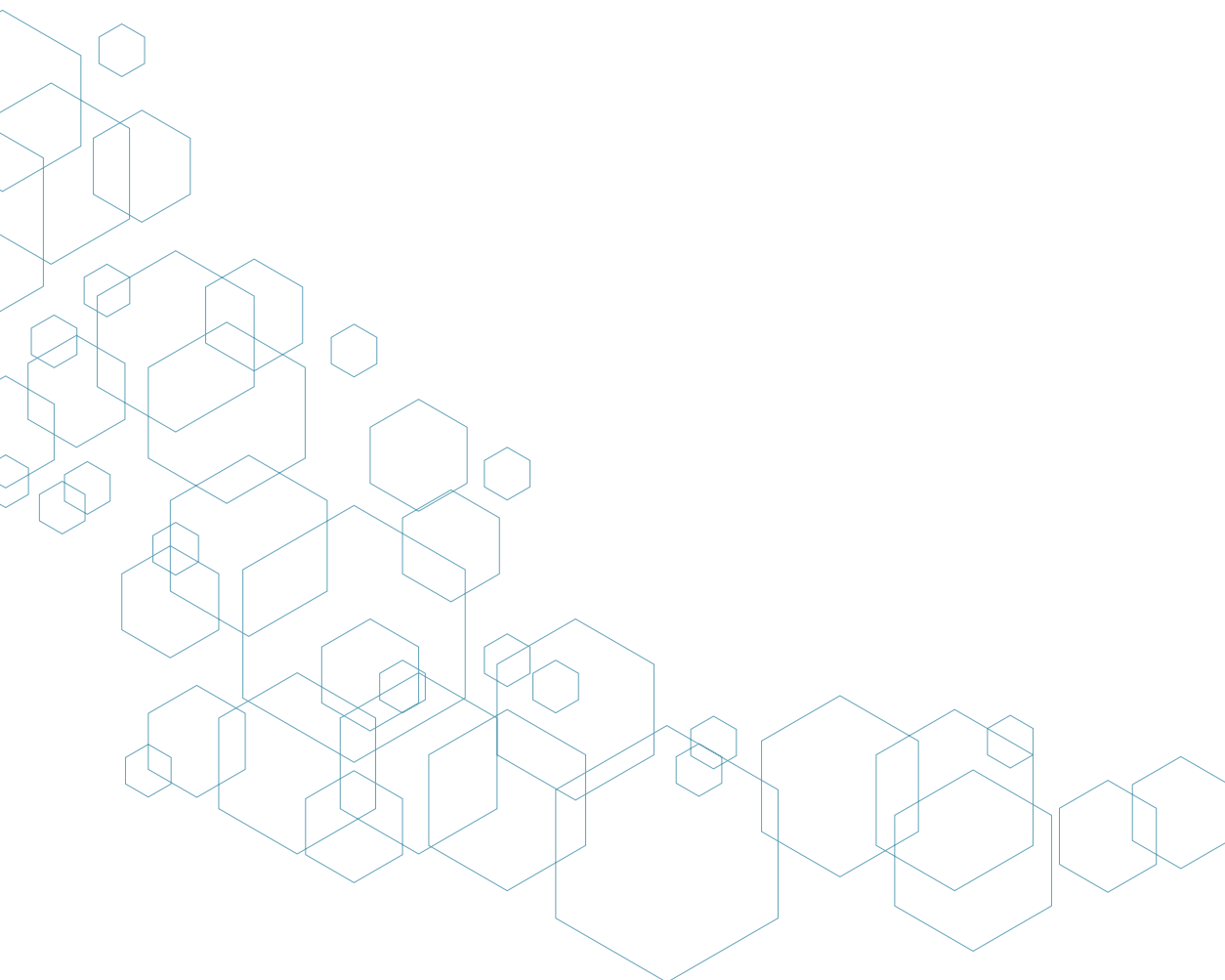

APPENDIX D: GLOSSARY OF TERMS, ABBREVIATIONS, AND ORGANIZATIONS



ACA	American Coatings Association
ACC	American Chemistry Council (Formerly the Chemical Manufacturers Association)
ACN	Acetonitrile
ABS	Acrylonitrile-Butadiene-Styrene
ACGIH	American Conference of Governmental Industrial Hygienists
Action Level	Action Level in the OSHA health standard for 1,3-butadiene “means a concentration of airborne BD of 0.5 ppm calculated as an eight (8)- hour time-weighted average.”
AIHA	American Industrial Hygiene Association
ANSI	American National Standards Institute
API	American Petroleum Institute
ASME	American Society of Mechanical Engineers
ASTM	American Society for Testing and Materials
Bonding	The connection of two or more conductive objects by means of a conductor (most commonly a wire or metal plate)
BLEVEs	Boiling Liquid Expanding Vapor Explosions
BTU	British Thermal Unit
CAA	Clean Air Act
CANUTEC	Canadian Transport Emergency Centre
CEPA	Canadian Environmental Protection Act
CERCLA	Comprehensive Environmental Response, Compensation, and Liability Act
CFR	Code of Federal Regulations
CG	Coast Guard
CHEMTREC	Chemical Transportation Emergency Center
CNS	Central Nervous System

Confined Space	An area that by design has limited openings for entry and exit. A confined space has unfavorable natural ventilation and is not intended for continuous worker occupancy.
CPC	Chemical Protective Clothing
DOT	Department of Transportation
DEHA	Diethylhydroxylamine
DMF	Dimethyl Formamide
DSL	Domestic Substances List (Canada)
EC	European Community
EPA	Environmental Protection Agency
EPCRA	Emergency Planning and Community Right-to-Know Act
ESD	Electrostatic discharge
EU	European Union
Flashpoint	The minimum temperature at which a liquid gives off vapor in sufficient concentrations to form an ignitable mixture with air near the surface of a liquid.
GC	Gas Chromatography
GLP	Good Laboratory Practices
Grounding	The connection of one or more conductive objects to the ground: a specific form of bonding. Grounding is also referred to as earthing.
HAP	Hazardous Air Pollutant
HMIS	Hazardous Materials Identification System
HAZWOPER	Hazardous Waste Operations and Emergency Response
HMDA	Hexamethylenediamine
HON	Hazardous Organic NESHAP
IDLH	Immediately Dangerous to Life or Health
IARC	International Agency for Research on Cancer
IATA	International Air Transport Association
ICAO	International Civil Aviation Organization
IISRP	International Institute of Synthetic Rubber Producers
IMDG	International Maritime Dangerous Goods
IMO	International Maritime Organization
ISGOTT	International Safety Guide for Oil Tanker and Terminals

ISO	International Standards Organization
LFL	Lower Flammability Limit
LLDPE	Linear Low Density Polyethylene
LPGs	Liquefied Petroleum Gases
MIL	Military
MMBS	Methyl Methacrylate-Butadiene-Styrene
MOPN	Methoxy-propio-Nitrile
MTBE	Methyl Tertiary Butyl Ether
NBR	Nitrile-Butadiene Rubber
NDE	Nondestructive Evaluation
NDT	Nondestructive Testing
NEC	National Electrical Code
NESHAP	National Emission Standards for Hazardous Air Pollutants
NFPA	National Fire Protection Association
NGL's	Natural Gas Liquids
NIOSH	National Institute for Occupational Safety and Health
NIST	National Institute of Standards and Technology
NMP	n-Methyl-2-Pyrrolidone
NOEL	No Observed Effect Level
NPRI	National Pollutant Release Inventory
NTP	National Toxicology Program
OSHA	Occupational Safety and Health Administration
PEL	Permissible Exposure Limit
PB	Polybutadiene
PBR	Polybutadiene Rubber
PM	Preventative Maintenance
PPE	Personal Protective Equipment
ppm	parts per million
ppmv	parts per million by volume
ppmw	parts per million by weight

psig	pounds per square inch gravity
REL	Recommended Exposure Limit (NIOSH)
RCRA	Resource Conservation and Recovery Act
RQs	Reportable Quantities
SCBA	Self-Contained Breathing Apparatus
SBS, SEBS	Styrene-Butadiene Block Copolymers
SBL	Styrene-Butadiene Latex
SBR	Styrene-Butadiene Rubber
SCC	Standards Council of Canada
SDS	Safety Data Sheet
SOCMI	Synthetic Organic Chemicals Manufacturing Industry
STEL	Short Term Exposure Limit
TBC	Tertiary Butyl Catechol
TLV	Threshold Limit Value
TOC	Total Organic Carbon
TPQ	Threshold planning quantity
TRI	Toxics Release Inventory
TSCA	Toxic Substances Control Act
TWA	Time-Weighted Average
UL	Underwriters Laboratory
Ullage	Amount by which a packaging falls short of being liquid full
UN	United Nations
USCG	United States Coast Guard
Vapor Pressure	The pressure exerted by a volatile liquid while under defined equilibrium conditions. Vapor pressure is usually measured in millimeters of mercury (mm Hg).
WHMIS	Workplace Hazardous Materials Information System (Canada)
4-VCH	4-Vinylcyclohexene