

---

# Exposure Control Guidelines in the Truck Bed Liner (TBL) Industry for Low Pressure System Applications

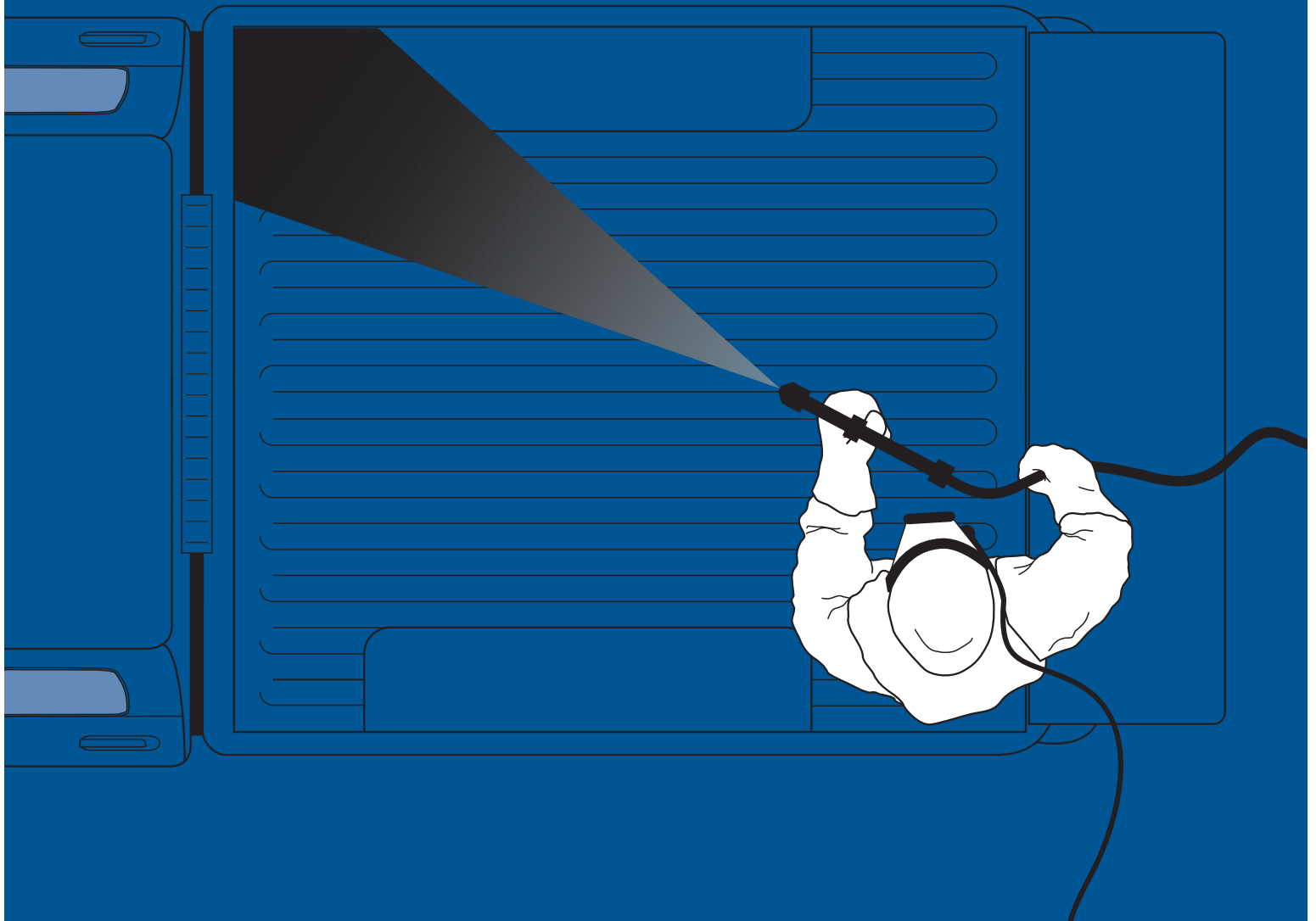

---

# Exposure Control Guidelines in the Truck Bed Liner (TBL) Industry for Low Pressure System Applications

The Center for the Polyurethanes Industry (CPI) has prepared these guidelines to provide general information and to explain the precautions and practices associated with the safe handling of methylene diphenyl diisocyanate (MDI) in the truck bed lining (TBL) industry during low pressure system applications. Specifically, this document will discuss engineering controls (e.g., adequate ventilation), personal protective equipment and general work practices common to the TBL industry.

These guidelines were developed as a supplement to the information provided in the supplier's Material Safety Data Sheet (MSDS), which is an important source of safe use and handling information for a product. This document is intended to provide helpful information, examples, and guidelines to users of MDI who are sophisticated users of chemicals and who know of the risks associated with the use of the chemicals. Such users should understand the information provided in the MDI suppliers' MSDS.

This information is limited to "solvent free" TBL low pressure system applications. Other applications of spray-on liner systems such as to cargo vans, boats, floors, etc., are not addressed in this document. Where applicable, other supporting documents are referenced.

These guidelines were written with the understanding that there are a large number of variables to consider in the spray application of truck bed liners. In other words, not all "shops" and not all systems are the same, making it a challenge to develop engineering guidelines or other control measures that would work for every location. Each facility has an independent obligation to ascertain that its plans, actions and practices meet all relevant laws. Further it is the responsibility of each facility to ensure compliance with the standards promulgated by the Occupational Safety and Health Administration (OSHA).

## I. Engineering Controls

Since engineering controls are identified as the primary compliance control over personal protective equipment (PPE) within the OSHA air contaminant standard<sup>1</sup> the following guidelines are offered to support the design of an enclosure "spray room" for applying low pressure MDI-based spray-on linings. They are based on industrial hygiene principles and practical experience, which have helped reduce the airborne MDI levels measured in the breathing zones of TBL applicators in some spray room enclosures.

---

<sup>1</sup> per 29 CFR §1910.1000(e) "To achieve compliance with paragraphs (a) through (d) of this section, administrative or engineering controls must first be determined and implemented whenever feasible. When such controls are not feasible to achieve full compliance, protective equipment or any other protective measures shall be used to keep the exposure of employees to air contaminants within the limits prescribed in this section..."

**(A) General Design**

The enclosure should be able to accommodate the size of the truck bed while allowing the applicator enough space to maneuver safely within it. The walls and main doors of the enclosure should close completely and the side walls of the enclosure and gaps under the truck should be sealed along with any other air leaks. This helps prevent chemical vapors/aerosols from escaping into the shop area. Of course, some openings may be necessary to accommodate a prescribed amount of make-up air. The amount and placement of make-up air openings is dependent upon the design of the enclosure and accompanying exhaust ventilation system.

While there is not a standardized method of enclosure design for controlling airborne MDI, what has been observed, is that the enclosure is generally effective when it maintains a negative pressure with respect to the outside environment. This is achieved by exhausting more air than is supplied (i.e., through the use of an exhaust ventilation system (hereinafter referred to as ventilation system)). The rate or speed of the air flowing into the enclosure is directly proportional to the type and size of fan used. Other factors also contribute to the rate of air flow. These will be discussed in Section (C).

In general, the enclosure should be designed so that the air flows across the top of the truck bed rails and is captured by the ventilation system. The flow direction can vary depending on the design of the enclosure but should provide a flow of "clean" air across the applicator's breathing zone, and preferably would not generate turbulent air currents within the application area. Even with an adequate ventilation system, workers should be advised to wear appropriate personal protective equipment (See Section II). The following sections outline some considerations for evaluating the enclosure.

**(B) Construction of the Spray Enclosure**

The construction of the enclosure can vary. If the materials being sprayed are not flammable (i.e., flashpoints are at or above 100°F) a paint spray booth for fire protection is not necessary per NFPA 33 (National Fire Protection Association) standards.

The enclosure may be constructed with rigid walls such as sheet metal or concrete block, or with a rigid frame, such as wood or steel pipe, and plastic curtains for walls. Fire-retardant polyethylene, with a minimum thickness of approximately 10 mils, may be used as the walls of the room. Generally, overspray from the application of the lining does not stick to the polyethylene surface allowing for easy peeling and removal of the cured overspray.

Finally, using light-colored plastic creates a brighter work environment in the enclosure. It may also be helpful to have the frame of the enclosure/room on the outside of the plastic curtains so that overspray does not build-up on the frame.

### (C) Checking for Leaks

The inside and the outside of the enclosure should be evaluated for leaks and system efficiency. This includes an evaluation of: (1) the main doors which should close completely; (2) cuts, tears or openings in the enclosure (unless intended specifically for make-up air); (3) unsealed side walls; (4) gaps under the truck; and, (5) any other air leaks which reduce the effectiveness of the ventilation. A smoke tube is a helpful tool for evaluating the air flow when designing the enclosure. This tool visually demonstrates contaminant capture, its flow within the enclosure and possible eddy currents. Another useful tool is an air velocity meter (i.e., velometer/anemometer) which can measure the air velocity within an enclosure and aid in identifying "dead spots" or areas with a fast air current that may be creating turbulence.



### (D) Air Flow

Air flow may be affected by a number of factors including, but not limited to: (1) the position of the ventilation system and the make-up air supply; (2) the size of the fan; (3) the size of the ducts; (4) the size and type of the filter material; and, (5) the opening/closing of overhead garage and other doors at the shop. An adjustable louver system, which is designed to affect the direction of the incoming make-up air flow, can provide a quick and inexpensive means to experiment with air flow direction. Further, observing the airflow with the aid of the smoke from a smoke tube while adjusting the louver system, could aid in the design of the air flow direction.

Ventilation measurements should be collected within the enclosure, when the truck is positioned for application, but prior to spray application. Particular attention should be given to the measurements near the breathing zone of the applicator. The location of these measurements will vary depending on the application method (e.g., Is the truck bed liner applied with the applicator standing inside the bed or outside the bed?).

As previously mentioned, if the truck bed is pulled into the enclosure and the cab remains outside, all open areas under the truck should be sealed to prevent air from flowing under the truck. Air flowing underneath the truck reduces the air velocity across the truck bed, which subsequently reduces the flow of "clean" air across the applicator's breathing zone. Plastic sections, with a minimum thickness of approximately 10 mils, attached to the front curtain with Velcro strips, have been shown to seal these areas effectively.

When applying a low pressure system, it is helpful to maintain a minimum air velocity of approximately 100 feet per minute (fpm) across the truck bed; however, maintaining an air velocity at this level or greater does not guarantee compliance with the OSHA permissible exposure limit (PEL) for MDI.<sup>2</sup> Personal protective equipment (PPE), therefore, should be used to protect applicators from potential overexposure to MDI during the application of the TBL system. Additional information about PPE is available in Section II of this document, as well as through the product MSDS and in literature posted on the CPI's Truck Bed Liner website at [www.spraytruckbedliner.org](http://www.spraytruckbedliner.org).

---

<sup>2</sup> The PEL for MDI is 0.02 parts per million (ppm) or 0.2 mg/m<sup>3</sup> as a Ceiling Limit or Ceiling Value (29 CFR §1910.1000, Table Z-1).

**(E) Determining Air Changes per Minute (ACM)**

Air changes per minute (ACM) is the ratio of the ventilation rate (per minute) to the room volume. The following examples are two methods for determining the ACM within a truck bed liner enclosure.

**Example 1:** To make this calculation you will need the “actual” fan rating (i.e., the cubic feet per minute (CFM) rating provided by the manufacturer of the exhaust fan).

1. Determine the volume of the enclosure in cubic feet, by multiplying the length x width x height; then,
2. Divide the fan CFM rating by the volume of the enclosure.

**Example 2:** To make this calculation you will need to determine the “calculated” CFM fan rating.

1. Determine the air velocity as feet per minute (fpm) at the face of the exhaust hood (i.e., exhaust unit opening), using an air velocity meter (e.g., velometer/anemometer) ---multiple points of measurement are needed across the plane to determine an average velocity;
2. Determine the “calculated” CFM by multiplying the area of the exhaust opening (sq. ft.) by the measured average air velocity (fpm);
3. Determine the volume of the enclosure in cubic feet, by multiplying the length x width x height; then,
4. Divide the “calculated” CFM by the volume of the enclosure.

Depending on the design and maintenance of the ventilation system, the “actual” CFM may be much different than the “calculated” CFM of the fan; thus, it is helpful to evaluate the ACM against the “calculated” CFM rating for the enclosure. An air change rate within the enclosure of 2-3 ACM common to this industry.

To “capture” overspray generated within the enclosure, filters are necessary. Air filters should be checked prior to any calculation, as dirty filters reduce air flow. Further, the outside exhaust location should be checked for blockage and placement. A manometer or pressure gauge can be used to monitor real-time changes in air flow and filter loading.

Exhaust filters should be replaced regularly (e.g., on a daily basis or when air flow measurements show a decrease in velocity).

#### **(F) Exhaust Fan**

The exhaust fan helps to maintain a volume and velocity of exhaust air sufficient to gather overspray from the truck bed lining process. Additionally it will help convey the overspray to suitable points of safe collection (i.e., captured by air filters), helping to prevent release of harmful quantities into the atmosphere. A tubeaxial fan, belt driven with an external totally enclosed fan cooled (TEFC) motor is often used. The fan should be placed outside the application room to avoid overspray build-up. Low cost particle arrestor filters are effective at capturing overspray droplets without restricting air flow. Several 1" thick filters (2-3) placed back-to-back are often used with success in the industry.

If possible, the exhaust fan should be placed next to the exterior exhaust point (e.g., on the roof or outside wall) so that it is pulling air through the ducting system. Installing the fan at a point too far upstream of the exterior exhaust point can put head pressure on the fan as it "pushes" the air through the duct work.

Fan blades should be inspected often (e.g., weekly) and cleaned on a regular basis. A clean blade will operate more efficiently. Unusual noises may indicate defective bearings, out of balance blades, or other maintenance issues. It also is prudent to periodically look for holes in the exhaust duct.

#### **(G) Ventilation Ducting**

The ducting system conveys the enclosure exhaust air to a suitable point of safe disposal. In most circumstances it is helpful if the exhaust system vents through the roof. If the system needs to go through a side wall of the building, it is best to install the exhaust duct above the roof line on the outside of the building.

The ducting for the ventilation system should be sized to maximize the air flow. A duct approximately 24" in diameter is useful, as smaller ducts could restrict air movement. Flexible ducts can restrict the exhaust air flow due to friction losses, while the smooth surface within a rigid metal duct generally does not. Multiple high angle (>45°) turns should be avoided as velocity and efficiency are lost when moving air is forced to make a turn.

#### **(H) Examples of Ventilation Systems**

In some cases, basic improvements to the size of the fan, ducting, or placement of the fan may be enough to reduce the airborne MDI level; however, in some cases, further modifications may be needed. A single exhaust fan, within a large enclosure, may not be sufficient to create enough air flow across the applicator's breathing zone, thus reducing the air velocity needed to "capture" the overspray vapors/aerosols at the generation point. In such instances, a directed air flow ventilation system, also known as a "push/pull" system may be needed to create higher air velocity across the breathing zone of the applicator. This type of system uses an exhaust fan, as described above, to "pull" air out of the room and a make-up air fan to "push" the "clean" air across the applicator's breathing zone. With proper placement of the push/pull system, enclosures may achieve air velocities in the work zone of 100-250 ft/min.

Suggested designs, for four TBL ventilation systems, are shown below as Figures 1-4. These do not represent the only methods for designing a ventilation system but are offered as examples that have demonstrated success at some spray-on truck bed lining operations. Each facility should assess its own plans, actions and practices in combination with the various TBL ventilation system options to determine the appropriate system for its facility and location.

**Figure 1**

Figure 1 depicts a common ventilation system design for the TBL industry which has had some success in meeting the OSHA PEL. In this system, the exhaust unit is in the front of the enclosure (Options A and B) with passive make-up air supplied primarily from the rear of the enclosure. The make-up air is being pulled into the enclosure from a designated location (i.e., the air should not be entering the enclosure by way of openings under the truck or from other locations that could compromise the air velocity in the applicator's breathing zone).

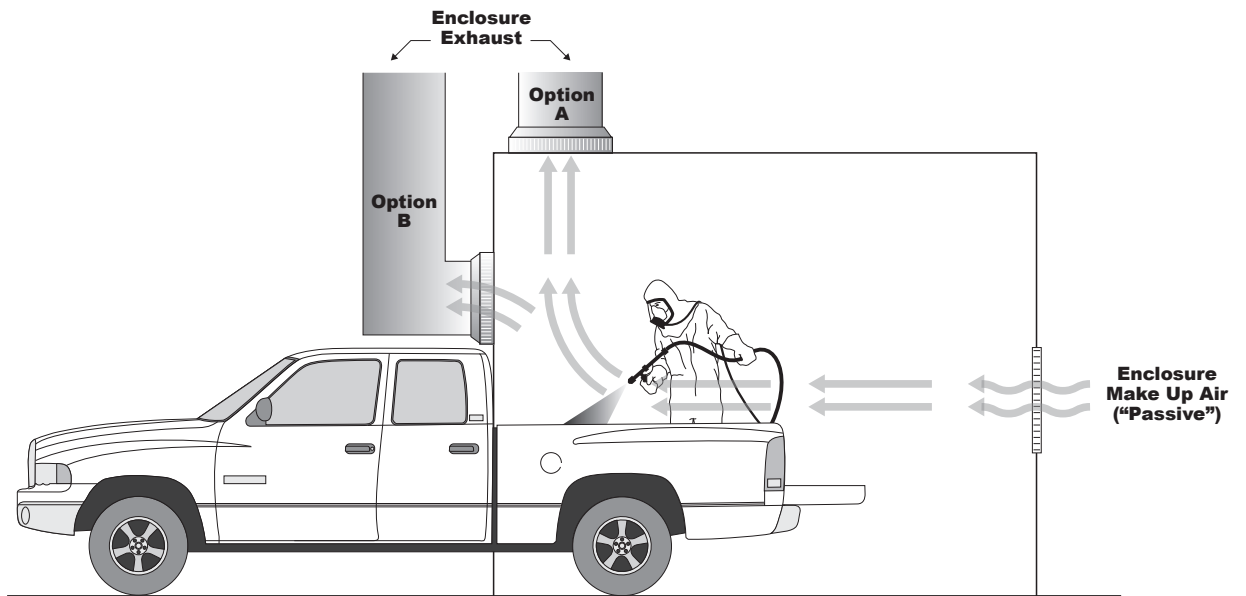

**Figure 2**

Figure 2 depicts another common ventilation system design for the TBL industry which has had some success in meeting the OSHA PEL. In this system, the exhaust unit is in the rear of the enclosure with passive make-up air supplied primarily in the front of the enclosure. With this design, the make-up air is being pulled into the enclosure from a designated location (i.e., the air should not be entering the enclosure by way of openings under the truck or from other locations that could compromise the air velocity in the applicator's breathing zone).

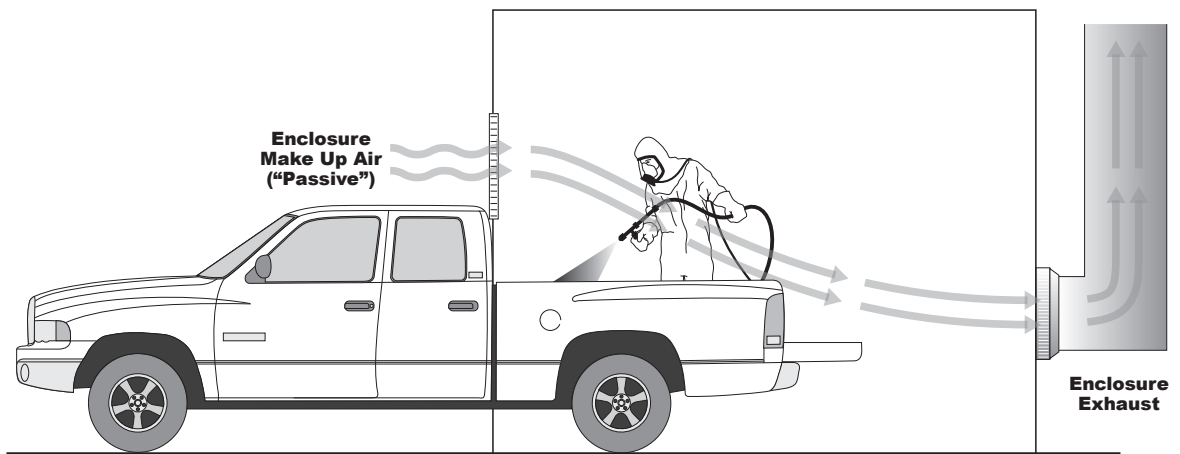

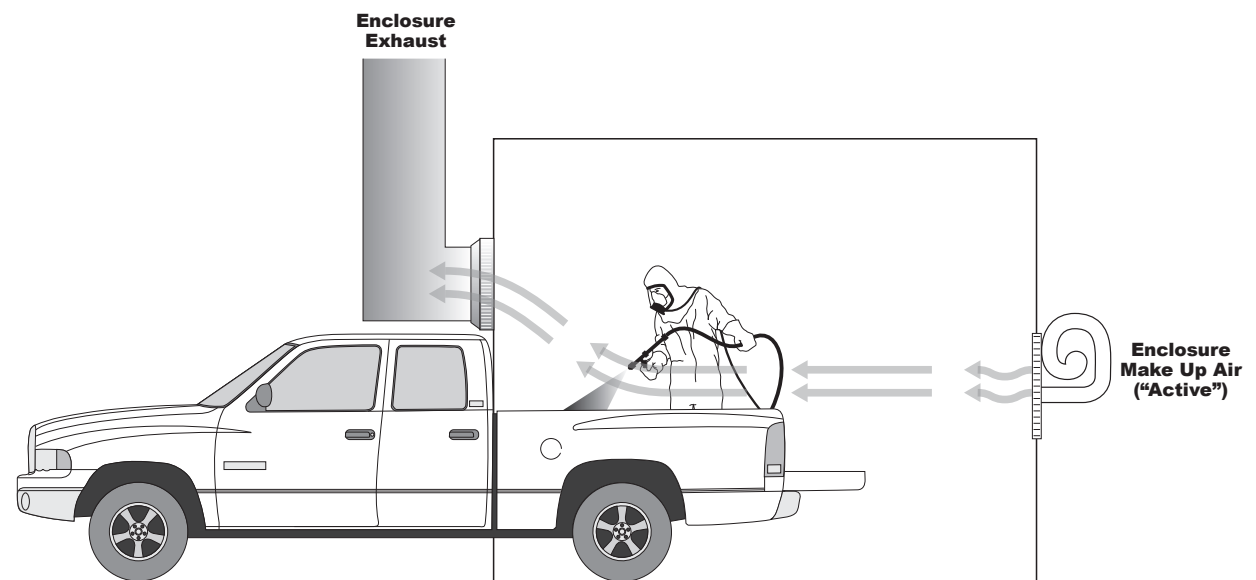

**Figure 3**

Figure 3 depicts an active air supply ventilation system designed to accelerate the air moving across the bed of the truck without disrupting the air flow to the point of causing turbulence. Turbulent air can worsen the air flow conditions in the applicator's breathing zone. In this system, one fan serves to exhaust the air out of the enclosure while a second fan serves to actively introduce make-up air into the enclosure. This system is often described as an "enclosure" push-pull ventilation system. For any exhaust system, the lack of an adequate amount of make up air can cause severe reduction in efficiency for the exhaust fan. When installing this type of system consider:

- The active make-up air fan should be approximately 50 percent of the airflow (i.e., CFM rating) of the exhaust fan. This will help to maintain the negative pressure condition within the enclosure. The remaining make-up air can be brought in with passive openings near or around the make-up air fan.
- Position the make-up air fan at the opposite end from the exhaust fan to create a push-pull air flow. Direct the air flow such that clean air is:
  1. Pushed across the applicator's breathing zone, and
  2. Located just above the truck rail height pushing the overspray containing MDI vapors/aerosols towards the exhaust fan opening. This helps to keep the overspray directed low and away from the applicator.

The make-up air fan also can introduce turbulence; therefore, a fan producing a laminar air flow should be chosen.



**Figure 4**

Figure 4 depicts an active air supply ventilation system designed to accelerate the air moving across the bed of the truck without disrupting the air flow to the point of causing turbulence. Turbulent air can serve to worsen the air flow conditions in the applicator's breathing zone. In this system one fan serves to exhaust the air out of the enclosure while a second fan serves to actively introduce an accelerated air stream across the bed of the truck. This system is best described as a "localized" push-pull ventilation system. For some exhaust systems, the lack of an adequate amount of make up air can cause a severe reduction in efficiency for the exhaust fan. When installing this type of system, consider:

- The active make-up air fan should be approximately 50 percent of the airflow (i.e., CFM rating) of the exhaust fan. This will help to maintain the negative pressure condition within the enclosure. The remaining make-up air can be brought in with passive openings near or around the make-up air fan.
- The air supply unit should be positioned near the truck bed rail at one of the corners near the cab. The exhaust fan will be at the opposite end of the enclosure to create a "localized" push-pull air flow. Direct the air flow so that it pushes air diagonally across the bed, at bed rail height. This helps to keep the overspray (MDI vapor/aerosol) directed away from the sprayer; the angle of the air flow is important in reducing the amount of overspray available within the applicator's breathing zone. Further, the applicator needs to be aware of the placement of the air supply unit so as to avoid positioning himself directly between it and the exhaust unit.

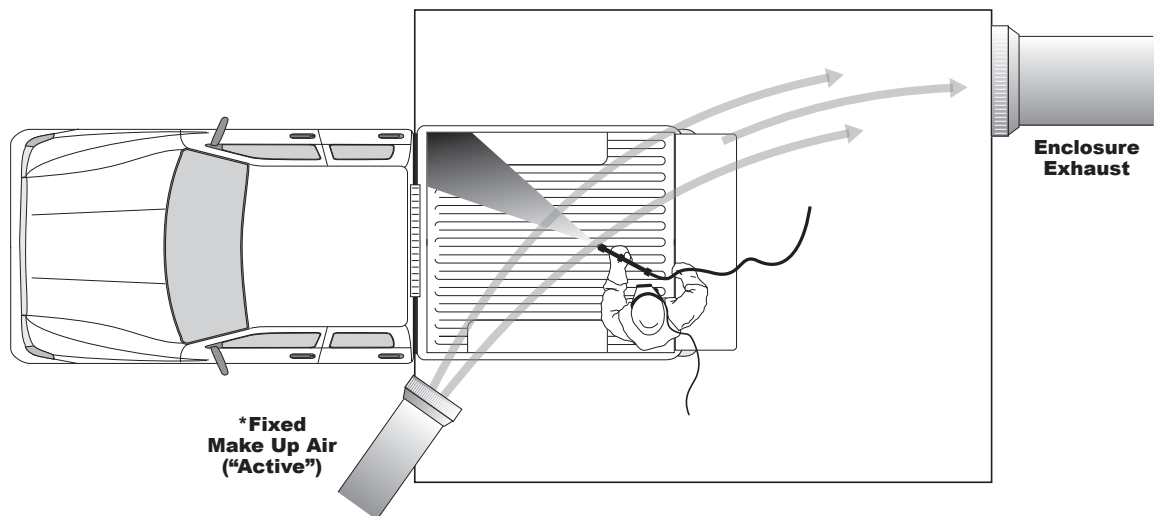

\* The volume of air supplied by this unit is dependent on the size of the enclosure exhaust unit, therefore the volume of make up air is determined on a case by case basis.

## II. Personal Protective Equipment

Even with effective engineering controls, applicators still need to wear appropriate personal protective equipment (PPE). This section provides general information about PPE. Though not exhaustive, the information provided may complement the information contained within your facility's safety program, as well as the system supplier's MSDS. A supplier's MSDS is an important source of safety and handling information for a product.

### (A) Recommended PPE

With proper precautions and the use of PPE, applicators can protect themselves from overexposure to MDI during the application of a TBL system.

- For tasks that do not involve spraying, such as cleaning equipment, use:
  - Safety glasses or goggles
  - MDI-resistant chemical gloves (e.g., nitrile)
  - MDI-resistant clothing (e.g., apron or coveralls)
  - Safety shoes or boots
- When spraying a truck bed liner system, use:
  - An approved supplied air respirator (as outlined in your company's respiratory protection program)<sup>3</sup>
  - Chemical goggles (in the absence of a full facepiece or loose-fitting hood)
  - MDI-resistant chemical gloves (e.g., nitrile)
  - MDI-resistant long-sleeve coveralls or full body suit with hood
  - MDI resistant fitted boots/booties

Workers not wearing the correct PPE should not enter the spray enclosure until the level of airborne MDI is below the OSHA PEL. Air samples, collected at specific time intervals after spray application has ceased, will aid in the determination of when it is safe to enter the enclosure.

### (B) Respiratory Protection

OSHA's Respiratory Protection Standard sets forth requirements for a facility Respiratory Protection Program (29 CFR §1910.134). A determination of the airborne MDI level will assist in the selection of appropriate respiratory protection, and will be needed to ascertain compliance with the OSHA PEL. The OSHA PEL for MDI is 0.02 parts per million (ppm) (0.2 mg/m<sup>3</sup>) as a Ceiling Limit or Ceiling Value (29 CFR §1910.1000, Table Z-1). If instantaneous monitoring is not feasible, then the ceiling limit is to be assessed as a 15-minute time weighted average exposure which shall not be exceeded at any time during the working day (29 CFR §1910.1000(a)(1)).



---

<sup>3</sup> The level of respiratory protection is dependant upon the airborne MDI concentrations measured during application of the TBL system.

Further, the American Conference of Governmental Industrial Hygienists (ACGIH), a nongovernmental voluntary guideline setting organization, has adopted a Threshold Limit Value (TLV) of 0.005 ppm (0.051 mg/m<sup>3</sup>) as an 8-hour Time Weighted Average (TWA). The TWA is a concentration to which it is believed workers may be repeatedly exposed for 8 hours a day, 40 hours a week, without adverse effect.

In accordance with OSHA's Respiratory Protection Standard (29 CFR §1910.134), a medical evaluation is required to determine fitness for respirator use. If a tight-fitting facepiece is selected, a fit test is then required. The fit test is conducted using the respirator to be worn on the job. Each time a tight-fitting facepiece is used, the applicator should conduct a 'user seal check'. Further, tight-fitting facepieces are not permitted for use if:

- Facial hair interferes with either the sealing surface of the respirator and the face, or with valve function;
- Corrective glasses/goggles or other personal protective equipment interferes with the seal of the facepiece; or
- Any other condition interferes with the facepiece seal.

Respirators should be regularly cleaned and disinfected according to the manufacturer's instructions. Deteriorated parts should be replaced prior to equipment use. Respirators should be inspected regularly for:

- Cracks, tears, holes, facemask distortion, cracked or loose lenses/face shield;
- Breaks, tears, broken buckles/clasps, overstretched elastic bands in head strap;
- Residue/dirt, cracks or tears in valve and absence of valve flap; and,
- Breathing air quality/grade, condition of supply hoses, hose connections, settings on regulators and valves.

Defective respirators or those with defective parts should immediately be taken out of service, and the supervisor should be notified.

The CPI has created a Model Respiratory Protection Program (MRPP), specific to the TBL industry, that can assist TBL application shops in the development of their own Respiratory Protection Program (refer to the Additional Information Section).

### III. Work Practices

Employee work practices are an important factor in the overall safety performance of a TBL shop; therefore, the following work practices should be reviewed with the shop employees involved in the spray application process.

Unless an emergency or unique circumstances require it, PPE should be removed only after exiting the spray enclosure and when cleanup is complete. Further, PPE should be worn while cleaning MDI-contaminated equipment and while handling any containers with MDI (e.g., drums, buckets, spray guns, etc). Some solvents can be harmful to unprotected skin, thus the appropriate glove should be chosen based on the solvent used. The type of PPE needed should follow the guidelines presented in the previous section.

A safety shower installation can help in situations where there is a potential for MDI exposure. The shower should be installed and maintained in accordance with ANSI Standard Z358.1.

It is a good work practice to keep work clothing at work. Any clothing contaminated with MDI should be removed and properly cleaned. Leather items cannot be decontaminated. Any contaminated leather items including shoes, belts, and watch bands or clothing, which have been exposed to MDI, should be properly discarded.

Good hygienic practices should be used to minimize the possibility of ingesting MDI. For example: the storage, preparation, or consumption of food in an area where MDI is used should be prohibited; and smoking, which may result in accidental ingestion of MDI by workers through the transfer of chemicals from hands or clothing to the mouth, should be prevented.

Procedures to follow during TBL application:

- Turn ventilation on prior to entering the spray enclosure.
- Stand upwind of the spray as much as possible.
- During start-up spraying, avoid using a bucket (or similar container) that creates blowback of vapors/aerosols.
- If the tailgate is removed from the truck for liner application, the applicator should be positioned upwind of the tailgate.
- After spraying, employees should not re-enter the spray enclosure unprotected (i.e., without the proper PPE) until airborne MDI vapors/aerosols have been reduced to appropriate levels (e.g., OSHA PEL). Clearance time will depend on the effectiveness of the ventilation system. For many systems that are effective and efficient, this is estimated to be within 5-10 minutes.
- Anyone entering the enclosure during spraying should be protected by the proper PPE.

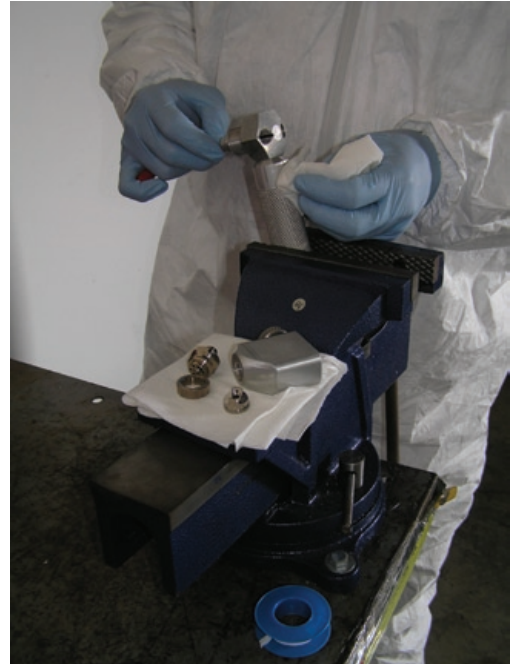

- During truck bed preparation (i.e., when the truck bed is sanded and wiped down) a solvent typically is used (e.g., denatured alcohol or acetone). Solvents may pose a fire/explosion hazard, and should be handled appropriately.
- PPE, such as respirators, should be properly cleaned and stored when work is complete.
- Overspray should be removed from walls on a regular basis to minimize material build-up. Removing dark overspray also keeps the room brighter which increases visibility for the applicator.

It is important to remember to act responsibly when handling MDI, or any chemical. Following established procedures, guidelines and precautions listed on documents, such as an MSDS, will help with proper handling. A listing of additional brochures and technical literature can be found at the end of this document. More information can be obtained by visiting CPI's website [www.americanchemistry.com/polyurethane](http://www.americanchemistry.com/polyurethane) or CPI's truck bed liner website: [www.spraytruckbedliner.org](http://www.spraytruckbedliner.org).

## Additional Information

For additional information on properties, protective clothing, safe handling, and disposal of MDI, consult the following sources:

- ACGIH Threshold Limit Values for Chemical Substances and Physical Agents & Biological Exposure Indices; Signature Publications, 1300 Kemper Meadow Drive, Cincinnati, OH 45240.
- Allport, D., Gilbert, D., and Outterside, S. (2003). MDI & TDI Safety, Health and the Environment. John Wiley & Sons, LTD, England.
- Current Supplier Material Safety Data Sheets (MSDSs) for methylene diphenyl diisocyanate (MDI).
- "Guide for the Primary Care Physician in Evaluating Diisocyanate Exposed Workers for Occupational Asthma." International Isocyanate Institute. The Scientific Office, Bridgewater House, Whitworth Street, Manchester M1 6LT. UK. April 1998.
- "Guidelines for the Responsible Disposal of Wastes and Containers from Polyurethane Processing," Alliance for the Polyurethanes Industry, 1300 Wilson Blvd. Arlington, VA 22209 (AX-151).
- "Guidelines for the Selection of Chemical Protective Clothing," American Conference of Governmental Industrial Hygienists, 1300 Kemper Meadow Drive, Cincinnati, OH 45240.
- "Hyperreactivity and Other Health Effects of Diisocyanates: Guidelines for Medical Personnel," Alliance for the Polyurethanes Industry, 1300 Wilson Blvd. Arlington, VA 22209 (AX-150).
- "Industrial Hygiene Air Monitoring for MDI and TDI" Alliance for the Polyurethanes Industry, 1300 Wilson Blvd. Arlington, VA 22209 (AX-248).
- Industrial Ventilation: A Manual of Recommended Practice – 24th Edition. The American Conference of Governmental Industrial Hygienists, Inc. (ACGIH), 1300 Kemper Meadow Drive, Cincinnati, OH 45240. ISBN: 1-882417-42-9, 2001.
- "MDI Transportation Guidelines," Alliance for the Polyurethanes Industry, 1300 Wilson Blvd. Arlington, VA 22209 (AX-198).
- "Model Respiratory Protection Program for Compliance with the Occupational Safety and Health Administration's Respiratory Protection Program Standard 29 CFR §1910.134: Truck Bed Liner," Alliance for the Polyurethanes Industry, 1300 Wilson Blvd. Arlington, VA 22209 (AX-246).
- OSHA Airborne Contaminants Standard: 20 CFR § 1910.1000
- OSHA Hazard Communication Standard: 29 CFR § 1910.1200.
- OSHA Personal Protective Equipment Standard: 29 CFR § 1910.132.
- OSHA Respiratory Protection Standard: 29 CFR § 1910.134.
- "PMDI User Guidelines for Chemical Protective Clothing Selection." Alliance for the Polyurethanes Industry, 1300 Wilson Blvd. Arlington, VA 22209 (AX-178).
- "Spray on Truck Bed Liner Applications Using MDI/PMDI; Seven Important Points." Alliance for the Polyurethanes Industry, 1300 Wilson Blvd. Arlington, VA 22209 (AX-405).
- "Truck Bed Liners: Worker Protection," Alliance for the Polyurethanes Industry, 1300 Wilson Blvd. Arlington, VA 22209.
- "Working with MDI and Polymeric MDI: What You Should Know," Alliance for the Polyurethanes Industry, 1300 Wilson Blvd. Arlington, VA 22209 (AX-205).

### **Disclaimer**

The purpose of this GUIDANCE DOCUMENT is intended to help explain some information about the safe handling of methylene diphenyl diisocyanate (MDI) during truck bed lining applications. The guidance is offered in good faith and is believed to be accurate and reliable as of the date of publication. This document is not designed or intended to define or create legal rights or obligations. The Center for the Polyurethanes Industry (CPI), of the American Chemistry Council, and its members do not make any warranty or representation, either express or implied, with respect to the accuracy or completeness of the information contained in this document. CPI disclaims and does not assume any liability of any kind whatsoever resulting from the use of or reliance on any information, conclusions, or opinions contained herein.

Center for the Polyurethanes Industry of the American Chemistry Council promotes the sustainable growth of the polyurethane industry, consistent with the principles of Responsible Care<sup>®</sup>, by identifying and managing issues that could impact the industry, in cooperation with user groups. Its members are U.S. producers or distributors of chemicals and equipment used to make polyurethane or are manufacturers of polyurethane products.

The American Chemistry Council (ACC) represents the leading companies engaged in the business of chemistry. ACC members apply the science of chemistry to make innovative products and services that make people's lives better, healthier and safer. ACC is committed to improved environmental, health and safety performance through Responsible Care<sup>®</sup>, common sense advocacy designed to address major public policy issues, and health and environmental research and product testing. The business of chemistry is a \$635 billion enterprise and a key element of the nation's economy. It is one of the nation's largest exporters, accounting for ten cents out of every dollar in U.S. exports. Chemistry companies are among the largest investors in research and development. Safety and security have always been primary concerns of ACC members, and they have intensified their efforts, working closely with government agencies to improve security and to defend against any threat to the nation's critical infrastructure.

